

Original Installation, Care and Maintenance BB-PEP Pump

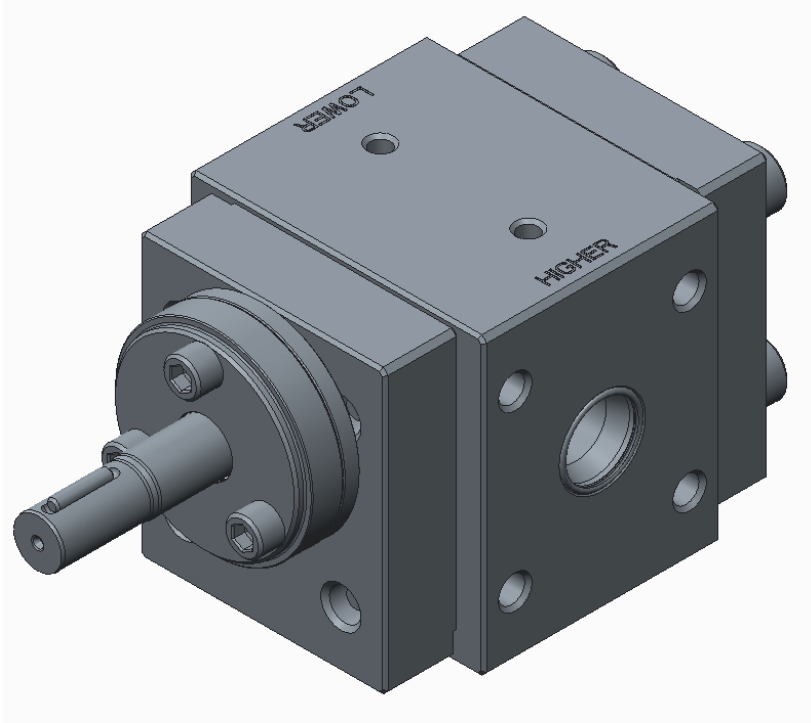

Zenith Pumps
1710 Airport Rd.
Monroe, NC 28110
USA

Phone: 1.704.289.6511

E-mail: CustomerCare@ColfaxCorp.com

Internet: <http://www.zenithpumps.com>



Document No. MAN-PEPB-ICM-ENGLISH
Document Rev. 2.0







WARNING

These instructions should be read thoroughly by specialized personnel prior to pump installation, operation, maintenance, assembly, or disassembly.

READ THIS ENTIRE PAGE BEFORE PROCEEDING

FOR SAFETY OF PERSONNEL AND TO PREVENT DAMAGE TO EQUIPMENT, THE FOLLOWING NOMENCLATURE HAS BEEN USED IN THIS MANUAL:

	DANGER	
Failure to observe the precautions noted in this box can result in severe bodily injury or loss of life.		
	WARNING	
Failure to observe the precautions noted in this box can cause injury to personnel by accidental contact with the equipment or liquids. Protection should be provided by the user to prevent accidental contact.		
CAUTION	ATTENTION	
Failure to observe the precautions noted in this box can cause damage or failure of the equipment.		
Non compliance of safety instructions identified by the following symbol could affect safety for persons: <div style="text-align: center;">  </div>	Safety instructions where electrical safety is involved are identified by: <div style="text-align: center;">  </div>	Safety instructions which shall be considered for reasons of safe operation of the pump and/or protection of the pump itself are marked by the sign: <div style="text-align: center;">  </div>

Contents

A.	OVERVIEW AND DISCLAIMER	2
B.	INTRODUCTION	2
C.	DESCRIPTION OF EQUIPMENT	2
D.	OPERATION	2
E.	SPECIFICATIONS	3
F.	DIMENSIONAL DIAGRAM	4
G.	PUMP MODEL IDENTIFICATION	4
H.	PUMP AND PART ORDERING INSTRUCTIONS	5
I.	INSTALLATION	5
J.	CLEANING PUMP FOR DISASSEMBLY	6
K.	DISASSEMBLY OF PUMP	6
M.	ASSEMBLY DRAWING	9
N.	REASSEMBLY OF PUMP	10
O.	BOLT TORQUE	12
P.	TROUBLESHOOTING	13

ATTENTION
If operation of this pump is critical to your business, we strongly recommend you keep a spare pump in stock at all times. As a minimum, a seal kit (o-rings, gaskets, and shaft seal) should be kept in stock so pump refurbishment after internal inspection can be accomplished.

A. OVERVIEW AND DISCLAIMER

The instructions found herein cover the disassembly, assembly and parts identification of Zenith BB-PEP pumps.

NOTE: Individual contracts may have specific provisions that vary from this manual. Should any questions arise which may not be answered by these instructions, refer to the Installation Care and Maintenance Manual provided with your order. For further detailed information and technical assistance please refer to Zenith Pumps, Technical/Customer Service Department, at (704) 289-6511.

This manual cannot possibly cover every situation connected with installation, operation, inspection, and maintenance of equipment supplied. Every effort was made to prepare the text of the manual so that engineering and design data is transformed into the most easily understood wording. Zenith Pumps must assume the personnel assigned to operate and maintain the supplied equipment and apply this instruction manual have sufficient technical knowledge and are experienced to apply sound safety and operational practices which may not be otherwise covered by this manual.

In applications where equipment furnished by Zenith Pumps is to become part of processing machinery, these instructions should be thoroughly reviewed to ensure proper fit of said equipment into overall plant operational procedures.



WARNING

If installation, operation, and maintenance instructions are not correctly and strictly followed and observed, injury to personnel or serious damage to pump could result. Zenith Pumps cannot accept responsibility for unsatisfactory performance or damage resulting from failure to comply with instructions.

B. INTRODUCTION

This instruction manual covers Zenith BB-PEP pumps. This series of pumps has been designed for use in polymer applications. The model and design construction of each pump can be identified by the part number on the pump's laser etching.

C. DESCRIPTION OF EQUIPMENT

The BB-PEP pump is constructed of two gears rotating in mesh within a closely fitted housing that is comprised of three plates. The center, or gear plate, fits closely around the outside diameter of the metering gears and bearings. The front and rear, or cover plates, sandwich the center plate and restrict axial movement of the gears and bearings. The driving gear is manufactured integral with the drive shaft, and the driven gear is machined integral with its shaft. The shafts are supported by "B" shaped bearings which fit into the center plate. One B-bearing fits on either side of the gears, supporting both the drive shaft and the arbor on both sides. The cover plates are secured to the center plate by 4 screws that go thru the center plate, and are threaded into the front cover plate. Each side of the center plate has a circular port in the center of a bolt circle for the mounting of adapter flanges that fit the pump to your equipment. A C-ring surrounds each port for sealing. Threaded holes are provided on the top and bottom of the center plate for the mounting of heat plates and for the mounting of the pump to its stand. An option is available to have cartridge heater holes integral to the center plate instead of attaching heater blocks. A Thermocouple well (1/8-27 NPT) is located on the rear cover plate of the pump. A Zenith Rheoseal assembly secured to the front cover plate prevents leakage around the shaft, using both dynamic and static types of sealing mechanisms. A Rheoseal consists of a helical groove on the inner diameter, a backup seal counter bore and gland. These spiral grooves allow the Rheoseal to act as a screw-type pump. As the fluid attempts to leave the gear pump, the shaft's rotary motion forces the fluid into the grooves. This creates a pressure greater than the pressure forcing polymer out of the pump, thus returning the polymer back towards the pump. Since the rotary motion is required of the shaft, two other static types of seals are employed on the Rheoseal—a spring energized lip-seal or a packing seal secured by the gland. An option is available for sealing with packing only. The packing seals are installed in the front cover plate, secured by a packing gland.

D. OPERATION

Polymer enters the BB-PEP pump on the suction side where shaft rotation exposes gear tooth volumes between the gear teeth. Polymer fills these spaces and is transported to the discharge side where the gear teeth mesh together, decreasing the gear tooth volumes and displacing the polymer. Due to the precision tolerances and close clearances within the rotating spaces, very high pressures can be achieved at the pump discharge with extremely high volumetric

efficiencies. As BB-PEP pumps rely on the metered polymer for lubrication of internal bearing surfaces, the operating speed is designed to be from 10 to 90 rpm on most extrusion processes depending on process parameters.

Do not allow the pump to run dry or attempt to pump poor lubricating fluids such as water or solvent.

When high-viscosity fluids are used, more time is required to fill the tooth volumes. As a result, the inlet pressure must be increased or the gears must rotate at a slower speed to ensure complete volume filling. Proper speed and inlet pressure must always be maintained to prevent cavitation and to ensure proper lubrication. Slip can occur across the sides of the gears from the high-pressure side to the low-pressure side. The amount of slip depends on four factors: polymer viscosity, speed, differential pressure and pump clearances. Under reasonably stable operating conditions, slip is repeatable and predictable, and pump operation can be adjusted to compensate.

E. SPECIFICATIONS

Pump Capacity	Operating Speed	Differential Pressure	Body Pressure	Maximum Temperature
cc/rev	RPM	psi (BAR)	psi (BAR)	°F
0.16	0-300	4800 (330)	4800 (330)	600 (950*)
0.3	0-300	4800 (330)	4800 (330)	600 (950*)
0.6	0-300	4800 (330)	4800 (330)	600 (950*)
1.2	0-300	4500 (310)	4500 (310)	600 (950*)
1.8	0-300	4500 (310)	4500 (310)	600 (950*)
3.0	0-300	4500 (310)	4500 (310)	600 (950*)
* With special fasteners and seals				

Never operate with fluids that are outside of the original design constraints, if there is any question contact Zenith Pumps immediately.

CAUTION	ATTENTION
<p>Operating conditions, such as speed, fluid viscosity, temperature, inlet pressure, discharge pressure, filtration, duty cycle, drive type, mounting, etc. are interrelated. Due to these variable conditions, the specific application limits may be different from that of the operational limitations. This equipment must not be operated without verification that operating requirements are within its capabilities.</p>	

F. DIMENSIONAL DIAGRAM

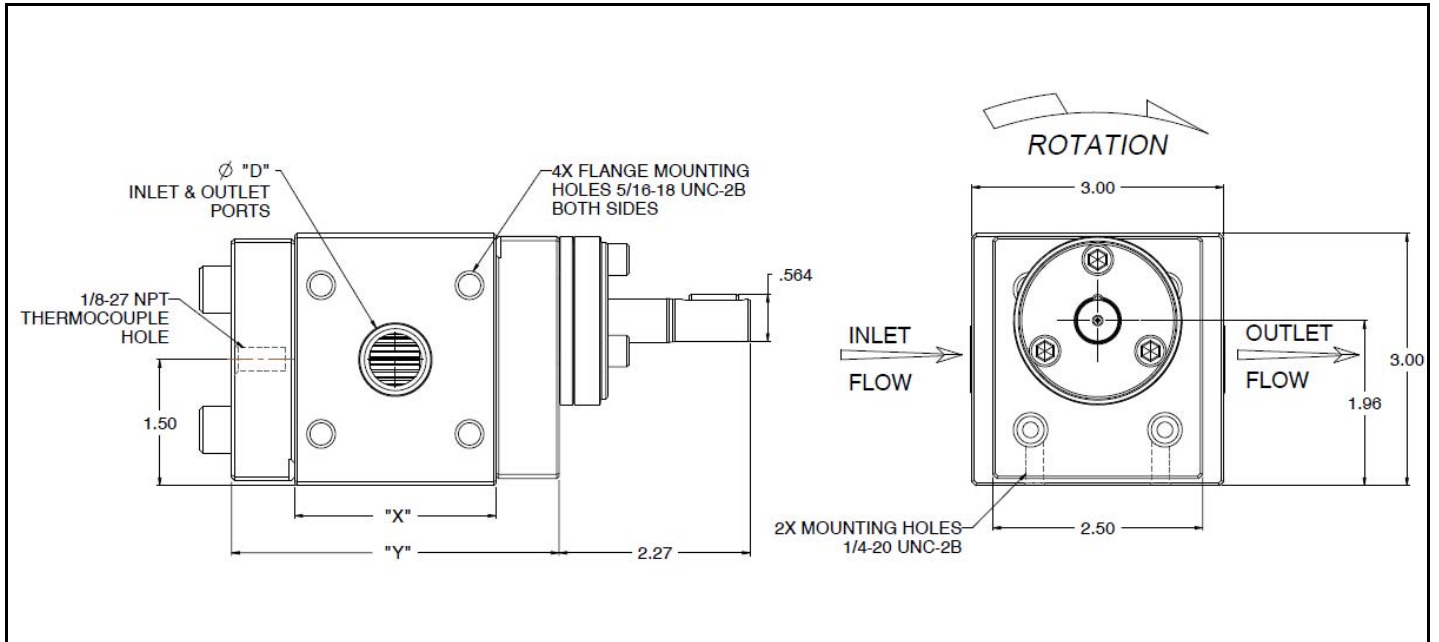

PUMP CAPACITY CC/REV	"X"	"Y"	"D"	APPROX WEIGHT
	IN.	IN.	IN.	LBS
0.16	1.61	3.11	0.125	7.9
0.3	1.61	3.11	0.125	7.6
0.6	1.61	3.11	0.250	7.5
1.2	2.40	3.90	0.750	9.7
1.8	2.40	3.90	0.750	9.4
3.0	2.40	3.90	1.000	9.1

G. PUMP MODEL IDENTIFICATION

This instruction manual covers the Zenith BB-PEP pumps. The model of each pump is identified on the pump's laser etching. See below for reference.

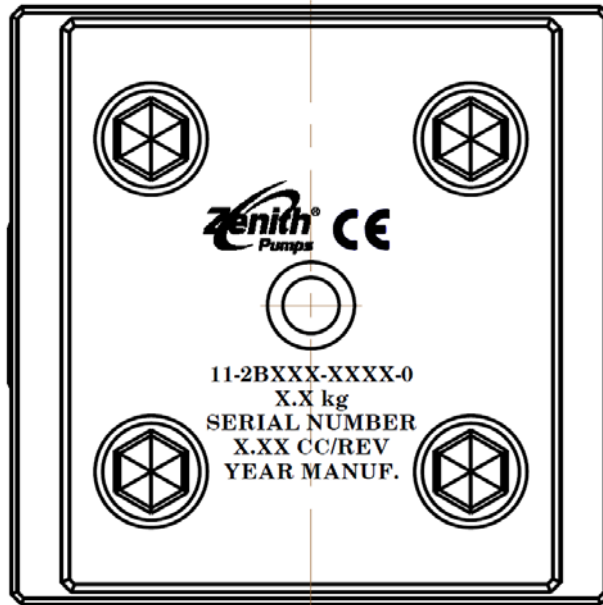

H. PUMP AND PART ORDERING INSTRUCTIONS

When corresponding with Zenith Pumps regarding Zenith BB-PEP pumps, refer to the pump's laser etching, this instruction manual, and the assembly drawing as instructed below:

1. From pump's laser etching, record the pump model number.
2. Record instruction manual number, revision and date.
3. From the instruction manual, record the figure numbers that apply to the replacement part(s).
4. From the assembly drawing or instruction manual (Assembly Parts List) provide the names for the replacement part(s).
5. Give the above information to your Zenith service representative.

I. INSTALLATION

Pumps should be carefully unpacked to make sure that the shipment is complete. If any items are missing or damaged, the freight carrier and Zenith should be notified immediately.

To prepare the pump for use:

- 1) Where required, install the heat plates as follows. Zenith-supplied heat plates are machined to tolerances that eliminate the need for heat transfer cement. All bolts used should be lubricated with high-temperature thread lubricant such as Never-Seez or equivalent.
- 2) Place the top heat plate on the pump, then place the insulation jacket on top of the heat plate. Install and tighten the bolts, taking care not to crack the insulation block.
- 3) Repeat for the bottom plate, noting that bottom heat plate mounting bolts are typically used to mount the pump to its mounting block.
- 4) Place the supplied metal O-rings into the counter-bores in the pump ports, and attach the inlet and discharge porting flanges with lubricated screws. Replace the O-rings after each use. Torque down the screws in a crisscross pattern, taking them first to 1/4 the recommended torque value, then to 1/2, to 3/4 and finally to their full recommended torque value as shown below. If the flanges are not supplied by Zenith, make certain that their mating faces are flat, with no pilots that protrude into the pump. Check that the pump rotates freely by turning the shaft with your hand.
- 5) The pump drive shaft should be connected to the motor drive assembly with a flexible coupling, a double universal joint shaft or an appropriate Zenith SJMC coupling. Side loading on the pump shaft is to be avoided at all costs.
- 6) Turn on the pump heaters. A 250° F temperature rise per hour is recommended for cold starts. No attempt should be made to start the pump until the entire pump is at operating temperature.

Cold starts are the most common cause of pump failure. On start-up, a small amount of molten polymer should be introduced into the pump by slowly rotating (less than 5 rpm) the pump by hand to ensure that the pump is free turning and well lubricated. With sufficient inlet pressure, the pump can then be started at a very slow speed, with discharge pressure low enough to maintain low loading. When operating satisfactorily, the pump and system may now be gradually brought up to normal process speeds and pressures.

J. CLEANING PUMP FOR DISASSEMBLY

CAUTION	ATTENTION
----------------	------------------

BB-PEP pumps are precision pumping devices made to close tolerances and will provide excellent service if applied correctly, handled carefully, and maintained. While the pump is composed of steel, it is a precision instrument. Dropping the pump or hitting with a non-yielding material can cause serious damage to the components. All materials are through-hardened to maximum hardness resulting in brittle material. Treat them as you would any other precision gauging instrument.

The pump normally must be cleaned for ease of disassembly. This can involve simply flushing the pump or a vacuum oven burnout at a maximum temperature of 900°F (482°C) in a protective atmosphere. Soak the pump in solvent (TEG for example for polyester) or heating to a moderate temperature of 300° to 600°F (150° to 315°C) to melt the process fluid and allow most of it to be flushed out of the pump. If a vacuum oven is available, the pump may be heated to higher temperatures to carbonize the polymer within the pump. Contact the factory for proper burnout temperatures.

Another acceptable cleaning method is to immerse the pump in a fluidized bed cleaning bath. The bath should be heated to a temperature that is sufficient to carburize the polymer. The carburization process usually takes between 3 to 12 hours, depending on the polymer type, temperature, pump size, and furnace load.

CAUTION	ATTENTION
----------------	------------------

Avoid exposing the pump to thermal shock when using this method of cleaning.

After gradually cooling to room temperature, the pump should be thoroughly flushed in a clean solvent. It may be necessary to disassemble the seal arrangement to remove polymer ash.

If the pump was performing satisfactorily when removed from service and still turns freely after burnout, pressure test it and add a high-temperature lubricant to prepare it for return to service. To store for future use, simply add rust preventative oil.

It is recommended that pump users institute a program of dimensional inspection of critical parts in order to keep maintenance and operating costs at a minimum. By noting the performance of a pump immediately before removing it from service and correlating the performance to the measured component wear, the user can establish the maximum wear limits for the pump's critical components. Further, he can predict the service life of the pump, and schedule downtime accordingly.

As with any other Zenith pump, BB-PEP Series pumps may be returned to Zenith for complete rehabilitation as necessary. This procedure may be desirable if only a few pumps are involved. Zenith offers a contract service program to repair and maintain your pumps. If a large number of pumps are to be maintained at the user's plant, it may be worthwhile to have key personnel attend a maintenance seminar at the Zenith factory to view the manufacturing, gauging, and assembly techniques involved in producing the BB-PEP Series pumps. Please contact Zenith for further information on contract repair service program or Maintenance seminar offerings.

In some cases spraying or soaking the pumps with one of several available penetrating oils can facilitate disassembly. Once cleaned, the pump is ready for disassembly.

K. DISASSEMBLY OF PUMP

CAUTION	ATTENTION
----------------	------------------

Zenith pumps require careful maintenance and handling, especially of component parts. The slightest burr, nick or particle of foreign matter can cause scoring or even seizure. Zenith pumps are precision instruments; you can't keep them too clean! Please treat them with care, and if it's at all possible, set aside a separate clean area for pump maintenance.

The pump should rest on its bottom surface during disassembly. Due care needs to be taken in choosing the surface on which the pump rests so as to prevent any damage to the pump. An alternative approach would be to clamp the pump into a large soft jaw vise, clamping on the front plate. The pump should be oriented with the drive shaft vertical, pointing down. Refer to assembly drawings and illustrations found in section M of this manual (general reference only).

1. Wash hands thoroughly or wear powder free latex gloves.
2. Ensure that you have a clean surface to work on.
3. Place pump assembly into a vice with soft jaws and orientate it so that drive shaft is pointing DOWN with the front plate being clamped. Remove the socket head cap screws.

CAUTION	ATTENTION
At this time the rear plate and gear plate are not held to the rest of the assembly! Avoid letting them fall from the assembly.	

4. Remove rear plate.

CAUTION	ATTENTION
If the rear plate is difficult to remove use a small pry bar in the area of the pry slot grooves on the corners. DO NOT go outside of this area! Doing so may result in the plates not being able to seal properly! Apply even pressure on both sides of the plate when removing it in this manner.	

NOTE: If the rear plate is difficult to remove please return the pump to Zenith Pumps.

5. Remove gear plate along with B-bearings, driving gear and shaft and driven gear and shaft.
6. The B-bearings, driving gear/shaft and driven gear/shaft can now be removed from the gear plate.

CAUTION	ATTENTION
Make sure there are no sharp corners or raised surfaces on the driving end of the drive shaft that could damage the lip seal as it slides over.	

CAUTION	ATTENTION
Handle all of these components with extreme care! Failure to do so could result in improper performance of the pump or even seizure.	

7. Remove B-bearings from drive shaft and arbor.
8. Reorient the front plate in the vise so that the seal housing bolts are accessible.
9. Remove the socket head cap screws holding the seal housing (or packing gland). Gently remove the seal housing (or packing gland) taking care not to damage the lip seal (or packing seals).
10. Slide lip seal (or packing seal) off of the drive shaft.

CAUTION	ATTENTION
Make sure there are no sharp corners or raised surfaces on the driving end of the drive shaft that could damage the lip seal as it slides over.	

11. Remove Rheo seal, or packing housing, depending on your pump type.

L. INSPECTION OF PARTS

After the parts have been cleaned, they should be inspected for nicks and burrs and stubborn residue. The gears and the edges of the center plate gear pockets are the most likely areas to be damaged because of the sharp edges. An illuminated magnifier facilitates the examination.

1. All flat surfaces of plates and gears should be "blocked." Blocking is the act of rubbing the flat surface of a part on 400-grit, 500-grit, or 3/0 abrasive paper, which is supported on a machinist's or inspector's surface plate. A few light but firm rubs usually is enough to remove the last of the residue and remove minor metal disturbances. Remember to use a figure 8 pattern to retain flatness and perpendicularity of holes when lapping plates.

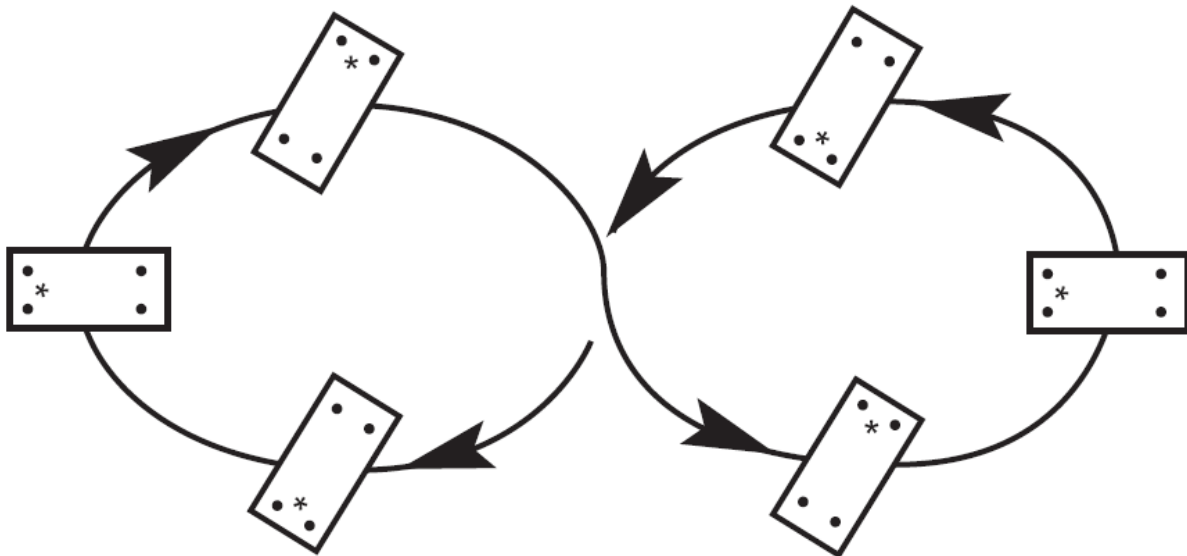

Heavy disturbances or residue on side plates (NOT gear plates!) may require stronger rubbing on 320-grit or even 240-grit abrasive paper followed by blocking on the finer abrasive. Deep score marks or metal transfer cannot be removed by blocking, and the surfaces must be ground. When surfaces are ground, care must be taken to maintain the perpendicularity of the precision ground holes with the inner plate surface. **Gear plates and B-bearings should never be ground;** to do so would reduce the axial gear clearance to the point where interference might occur when the pump was assembled. **Gears are integral and can not be removed from the shaft and arbor. Grinding of gears is not recommended.**

2. Gears, shafts, and arbors should be lightly polished on the O.D.
3. Any nicks in the gear teeth should be removed by careful stoning with a fine India oilstone or an Arkansas stone.
4. The edges of gear teeth, bearing holes, and dowel holes may be lightly stoned with a round Arkansas stone to remove any nicks. Then polish the I.D.'s with a small piece of fine abrasive paper.
5. After all preparation has been completed; remove the abrasive grain and loose residue in an ultrasonic cleaner or other suitable cleaning method. Abrasive grain is larger in size than the pump's clearances.
6. At this point, dimensional inspection may be made if desired.

M. ASSEMBLY DRAWING

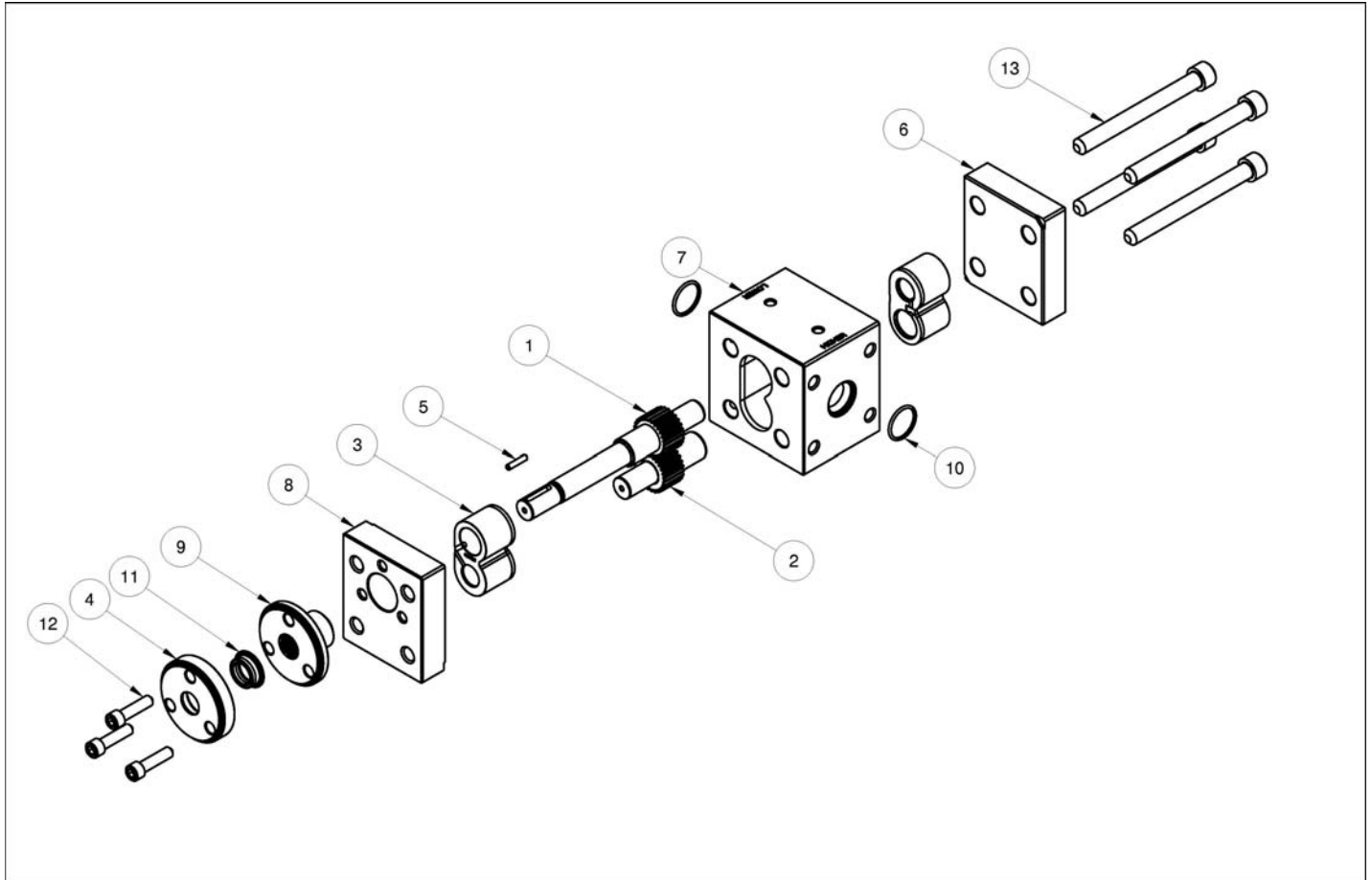

ITEM NO.	PART NAME	QTY
1	DRIVING GEAR/SHAFT	1
2	DRIVEN GEAR/ARBOR	1
3	B-BEARING	2
4	LIP SEAL HOUSING	1
5	KEY, ROUND	1
6	PLATE, REAR	1
7	PLATE, GEAR	1
8	PLATE, FRONT	1
9	SEAL, RHEO RH	1
10	C-RING	2
11	LIP SEAL	1
12	SHCS 1/4-20 X .750 ALLOY	3
13	SHCS 3/8-16 X 4.00 ALLOY	4

N. REASSEMBLY OF PUMP

CAUTION	ATTENTION
READ THIS ENTIRE PROCEDURE BEFORE ASSEMBLING PUMP	

NOTE: Inspect all running surfaces for scratching, scoring and wear prior to assembly of pump. Minor scratching is acceptable. If parts are heavily scratched or scored, they should be replaced. Thoroughly clean all pump components.

	WARNING
Follow the supplier's recommendations when using cleaning fluids.	

NOTE: Zenith Pumps recommends replacement of all "o" rings and seals every time these parts are disturbed from their original installed position.

NOTE: Refer to "Inspection of Parts" for additional information on part inspection and replacement. Wipe all parts with light lubricating oil to assist in assembly.

NOTE: Prior to assembly, remove all nicks and sharp edges on housings and gears with de-burring stone. Avoid excessive breaking of edges at outside diameter of gears as this could negatively affect flow rate.

1. Refer to the exploded view in section M of this manual. Install the front plate in a vice, oriented so that the three seal housing bolt holes are facing upward.
2. Install the lip seal in the seal housing by pressing it in firmly with your fingers. (Install packing seals in the seal housing for a packing seal version).
3. Install the lip seal housing on the Rheo seal ensuring that the lip seal flange contacts the Rheo seal face.
4. Install the seal assembly so that the Rheo seal or packing housing passes through the front plate and the seal flange contacts the front plate.
- 4.
5. Lubricate the seal housing bolt threads and under the bolt heads with high-temperature thread lubricant. Insert the seal or packing housing bolts and tighten the four binder screws in four stages in a crossing pattern until full bolting torque is reached. See table below for proper bolt torque loading. (If using a packing seal, install the packing gland and finger tighten the screws.)
6. Reposition the front plate in the vice so that the seal assembly is on the bottom with the shaft bore oriented vertically.
7. Grasp a B-bearing and install the shaft, drive-end first, through the larger B-bearing bore. The "Zenith" logo etching on the B-bearing should be clearly visible with the gear resting against the opposite face of the B-bearing.
8. Insert the smaller diameter end of the arbor into the smaller B-bearing bore. Align the shaft and arbor gears with meshed teeth so that both gear faces rest against the face of the B-bearing and the "Zenith" logo etching on the B-bearing is clearly visible on the opposite face.
9. Install the second B-bearing so that both the shaft and arbor pass through the associated B-bearing bores and the "Zenith" logo etching is clearly visible on the exposed face of the B-bearing.

CAUTION	ATTENTION
Make certain that there are no contaminants on the surfaces of the gears, B-bearings or cover plates. A minute piece of debris will cause the pump to bind.	

- Place lubricant onto the shaft end. Holding the assembly by the B-bearings, carefully install the shaft through the front plate and seal assembly. Ensure that the seal nose pilots into the B-bearing and that the B-bearing face rests flush with the front plate.

CAUTION	ATTENTION
Make sure there are no sharp corners or raised surfaces on the driving end of the drive shaft that could damage the lip seal as it slides over.	

- Install the gear plate over the B-bearings and gears. Ensure orientation as shown with the "LOWER" and "HIGHER" markings on top and flat part of the B bore to the left when facing the front of the pump.

CAUTION	ATTENTION
Make certain that there are no contaminants on the surfaces of the gears, B-bearings, or cover plates. A minute piece of debris will cause the pump to bind.	

CAUTION	ATTENTION
Do not force the gear plate over the bearings and gears. They will slip into place if properly aligned.	

- Position the rear cover plate on the gear plate, ensure thermocouple port is facing outwards.
- Lubricate the binder screw threads and under the screw heads with high-temperature thread lubricant.
- Install the binder screws and tighten to finger tight only. The gears should now spin freely when the drive shaft is rotated.
- Tighten the four binder screws in four stages in a crossing pattern until full bolting torque is reached. See table below for proper bolt torque loading.

CAUTION	ATTENTION
Each bolt should be torqued to $\frac{1}{4}$ of the recommended torque, $\frac{1}{2}$, $\frac{3}{4}$ then full torque. Each bolt should be torqued at least three times during this process to ensure proper bolt loading. Final tightening should be done with a torque wrench.	

- Pour oil into the inlet port to lubricate the internal components, and then rotate the pump to check for free rotation. If there is a problem, release the binder screws and check the internal components for damage. Disassemble per the previous instructions.

O. BOLT TORQUE

Size (UNC Alloy Steel)	Recommended Torque (in -Lbs)*	(Nm)*
#10-24	43	5
#12-24	68	7
1/4-20	103	12
5/16-18	213	24
3/8-16	378	43
1/2-13	922	104
5/8-11	1836	207
3/4-10	3257	368
Size (Metric Alloy Steel)	Recommended Torque (in -Lbs)*	(Nm)*
M3	12	1.4
M5	56	6.3
M6	96	11
M8	232	26
M10	460	52
M12	803	91
M16	1993	225

*Screws lubricated with high temperature thread lubricant, anti-seize compound.

P. TROUBLESHOOTING

Trouble	Probable Cause	Remedy
Pump will not turn	Process temperature too low	Check thermocouple and control loop for proper setting or operation.
	Drive malfunction	Verify that drive is powered. Assure that alarm circuits are clear. Check motor drive current and speed settings. Check drive couplings.
	Process conditions changed	Check process fluid for proper melt temperature.
	Entrained particle	Disassemble and clean pump. Replace any damaged parts.
	Internal damage	Disassemble and clean pump. Replace damaged parts.
	Incorrect installation	Check mounting arrangement. Check evenness of heating. Shaft Alignments
	Lack of lubrication	Journal bearing design may not be adequate.
	Interference fit of moving part	Measure clearances and correct if possible.
No flow from pump	Same as above	Same as above.
	Pump rotation	Correct drive arrangement or power leads.
Reduced Pump Efficiency	Worn gear(s)	Replace worn gear(s).
	Worn side plate(s)	Resurface or replace worn plate(s).
	Worn gear plate	Replace gear plate.
	Worn shaft and/or bearing holes causing excessive leakage	Replace shaft and/or side plate(s).
Seal Leakage	Worn or scratched seal faces	Resurface or replace.

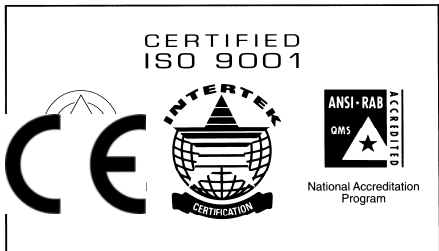

Zenith Pumps
1710 Airport
Road
Monroe, NC 28110 USA
Tel: 704.289.6511
zenithpumps.com

© 2017 Zenith Pumps All rights reserved.