



9000 SERIES GEAR PUMPS

PRECISE, PULSELESS, REPEATABLE METERED FLOW CONTROL



PUMPS SUITED FOR YOUR APPLICATION

Your demanding application requires a precise volume of fluid dispensed – reliably, accurately and consistently. The Zenith 9000 Series metering gear pump is the industry standard for true precision metering for challenging applications in a wide variety of industrial processes.

For years, engineers just like you have relied on Zenith to provide precision fluid handling solutions for the most difficult pumping applications. That's why Zenith gear pumps can be found wherever precise, pulseless and reliable fluid metering performance is required.

TECHNOLOGY THAT WORKS FOR YOU

The design utilizes high AGMA standard external spur gears enclosed within a close tolerance housing assembly. This provides you the precise volume of fluid dispensed per shaft revolution.

The housing is constructed from a precision ground and lapped three-plate assembly. This assembly is aligned with dowels to allow close control of operating clearances. This construction method in combination with several proprietary internal features is what ensures precise, pulseless and reliable flow under varying process conditions. When Zenith pumps are coupled with a pre-packaged, integrated, closed-loop speed control and a compact motor driver assembly (AC or DC), Zenith is able to provide the most precise and flexible metering gear pump system on the market.

A LEGACY OF RELIABILITY

Zenith has designed and manufactured precision metering gear pumps for demanding applications like yours since its inception in 1926. The 9000 series is Zenith's latest generation of industrial metering pumps that is based upon years of practical application knowledge, and pioneering research and development.

CIRCOR: LEADING TECHNOLOGY, GLOBAL CAPACITY

You may know CIRCOR best by our strong legacy brands that include Zenith, Imo, Allweiler and Houttuin. We serve customers just like you at facilities, manufacturing sites and distribution centers throughout the Americas, Europe, Africa, the Middle-East and Asia Pacific. Our global network of critical fluid handling technologies, solutions, services and support are unmatched in the industries that we serve. The CIRCOR team in each of these regions understand the challenges you face, respects the high stakes of mission critical equipment and stands ready to deliver with the fluid handling solutions you need.

When precision is mandatory and failure not an option, the most trusted name in critical fluid handling is CIRCOR.



B-9000 SERIES



GENERAL-PURPOSE INDUSTRIAL DUTY CONSTRUCTED OF THROUGH HARDENED 400 SERIES SS

CAPACITIES (CC/REV)

0.05, 0.3, 0.6, 1.2, 2.4, 4.5, 9.0, 15, 30, 45, 90

RECOMMENDED SPEED

0.05 to 30 cc/rev, up to 500 RPM
45 & 90 cc/rev, up to 300 RPM

FLOW RANGE

up to 27,000 cc/minute (up to 7 GPM)

INLET PRESSURE

Flooded to 300 psi (20 Bar) Maximum

OUTLET PRESSURE

1,000 psi (70 Bar) Maximum

DIFFERENTIAL PRESSURE

20 to 1,000 psi (viscosity dependent)

TEMPERATURE

0° F (-18° C) Minimum,
400° F (205° C) Maximum (with magnetic coupling seal);
645° F (340° C) Maximum (dependent in shaft seal materials)

SEALS

Single Mechanical, Double Lip, Packing or Magnetic

ROTATION

Clockwise (CW) facing drive shaft

PORT CONNECTIONS

ISO 6149 or 6162 Standard

Optional Port Adapters

M12 X 1/4" NPT	0.05 – 2.4 cc/rev
1/2" SAE X 1/2" NPT	4.5 – 9.0 cc/rev
3/4" SAE X 3/4" NPT.	15 – 30 cc/rev
1-1/4" SAE X 1-1/4" NPT	45 – 90 cc/rev

Optional Band Heaters

150 Watt, 115 VAC	0.05 – 2.4 cc/rev
325 Watt, 115 VAC	4.5 – 9.0 cc/rev
650 Watt, 230 VAC	15 – 30 cc/rev
1,500 Watt, 230 VAC	45 – 90 cc/rev

Applications

DYES	ISOCYANATE	COSMETICS	INKS	COATINGS
PERFUMES	VISCOSE	FUELS	URETHANES	LUBRICANTS
ADHESIVES	FLAVORINGS	RESINS	CATALYSTS	HOLLOW FIBER
POLYMERS	PAINTS/VARNISHES	OILS	VITAMINS	DETERGENTS
EMULSIONS	DEFOAMERS	INHIBITORS	ADDITIVES	MANY MORE...

C-9000 SERIES

CORROSIVE AND POOR LUBRICATING FLUIDS CONSTRUCTED OF HARDENED 316 SS AND COMPATIBLE MATERIALS

CAPACITIES (CC/REV)

0.3, 0.6, 1.2, 2.4, 4.5, 9.0

RECOMMENDED SPEED

up to 1,000 RPM

FLOW RANGE

up to 9,000 cc/minute (up to 2.4 GPM)

INLET PRESSURE

Flooded to 300 psi (20 Bar) Maximum

OUTLET PRESSURE

1,000 psi (70 Bar) Maximum

DIFFERENTIAL PRESSURE

20 to 1,000 psi (viscosity dependent)

TEMPERATURE

-40° F (-40° C) Minimum, 350° F (175° C) Maximum

SEALS

Single Mechanical, Double Lip or Magnetic

ROTATION

Clockwise (CW) facing drive shaft

PORT CONNECTIONS

ISO 6149 or 6162 Standard

Optional Port Adapters

M12 X 1/4" NPT 0.3 – 2.4 cc/rev
1/2" SAE X 1/2" NPT 4.5 – 9.0 cc/rev

Optional Band Heaters

150 Watt, 115 VAC 0.3 – 2.4 cc/rev
325 Watt, 115 VAC 4.5 – 9.0 cc/rev

ACIDS	VITAMINS	PERFUMES	FUELS	ADDITIVES
BASES	PHARMACEUTICALS	FUELS	FLAVORINGS	SOLVENTS
COATINGS	HOLLOW FIBER	COSMETICS	OILS	MANY MORE...

H-9000 SERIES

HIGH-TEMPERATURE AND ABRASIVE FLUIDS

CONSTRUCTED OF THROUGH HARDENED HIGH-SPEED TOOL STEELS

CAPACITIES (CC/REV)

0.05, 0.3, 0.6, 1.2, 2.4, 4.5, 9.0, 15, 30, 45, 90

RECOMMENDED SPEED

0.3 to 30 cc/rev, up to 500 RPM

45 & 90 cc/rev, up to 300 RPM

FLOW RANGE

up to 27,000 cc/minute (up to 7 GPM)

INLET PRESSURE

Flooded to 1,000 psi (70 Bar) Maximum

OUTLET PRESSURE

2,500 psi (175 Bar) Maximum

DIFFERENTIAL PRESSURE

20 to 2,500 psi (viscosity dependent)

TEMPERATURE

32° F (0.0° C) Minimum, 950° F (510° C) Max.

(With packing seal and high temperature fasteners)

SEALS

Single Mechanical, Double Lip seal or Packing configurations

ROTATION

Clockwise (CW) facing drive shaft

PORT CONNECTIONS

ISO 6149 or 6162 Standard

Optional Port Adapters

M12 X 1/4" NPT	0.3 – 2.4 cc/rev
1/2" SAE X 1/2" NPT	4.5 – 9.0 cc/rev
3/4" SAE X 3/4" NPT	15 – 30 cc/rev
1-1/4" SAE X 1-1/4" NPT	45 – 90 cc/rev

Optional Band Heaters

150 Watt, 115 VAC	0.3 – 2.4 cc/rev
325 Watt, 115 VAC	4.5 – 9.0 cc/rev
650 Watt, 230 VAC	15 - 30 cc/rev
1,500 Watt, 230 VAC	45 - 90 cc/rev

ADHESIVES	FOAMS	URETHANES	PLASTICIZERS	MONOMERS	SEALANTS
ADDITIVES	COATINGS	SURFACTANTS	POLYOLS	OILS	TACKIFIERS
ASPHALT	INKS	OXIDE SLURRIES	PLASTICS	PIGMENTS	NON-WOVENS
ABRASIVES	FIBERS	LUBRICANTS	PAINTS	TARS	RELEASE AGENTS
BOTTOMS	PITCH	POLYMERS	RESINS	MANY MORE...	

BENEFITS THAT GO STRAIGHT TO YOUR BOTTOM LINE

HIGH ACCURACY	Stable, repeatable flows are assured under varying conditions of temperature, viscosity and pressure.
UNIFORM FLOW	Unique design offers virtually pulseless flow without valves or flexible elements that add complexities, increase cost and hinder performance.
SPECIFIC ENGINEERED SOLUTIONS	A variety of pump heads and drive combinations are pre-configured to provide you a range of standard options.
CONSISTENT PRECISION	Unparalleled mechanical precision, combined with closed-loop accuracy, ensures exact volume per revolution without expensive flow meters.
LOW COST OF OWNERSHIP	Only three moving parts and hardened abrasion resistant materials provide excellent wear, corrosion and self-lubricating performance
PROVEN APPLICATIONS	Years of practical application experience, backed by a technical staff with a variety of technical credentials, eliminates the guesswork.

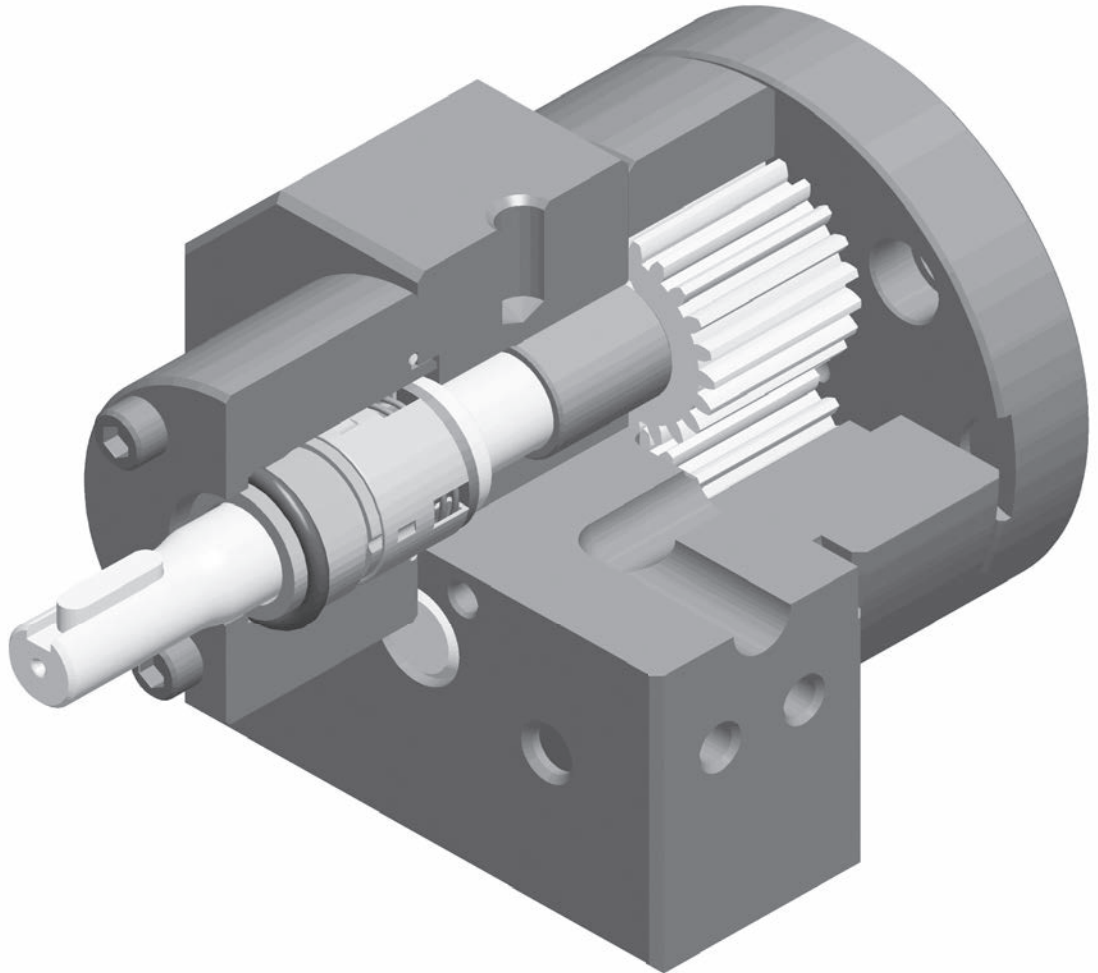

PUMP DIMENSIONS

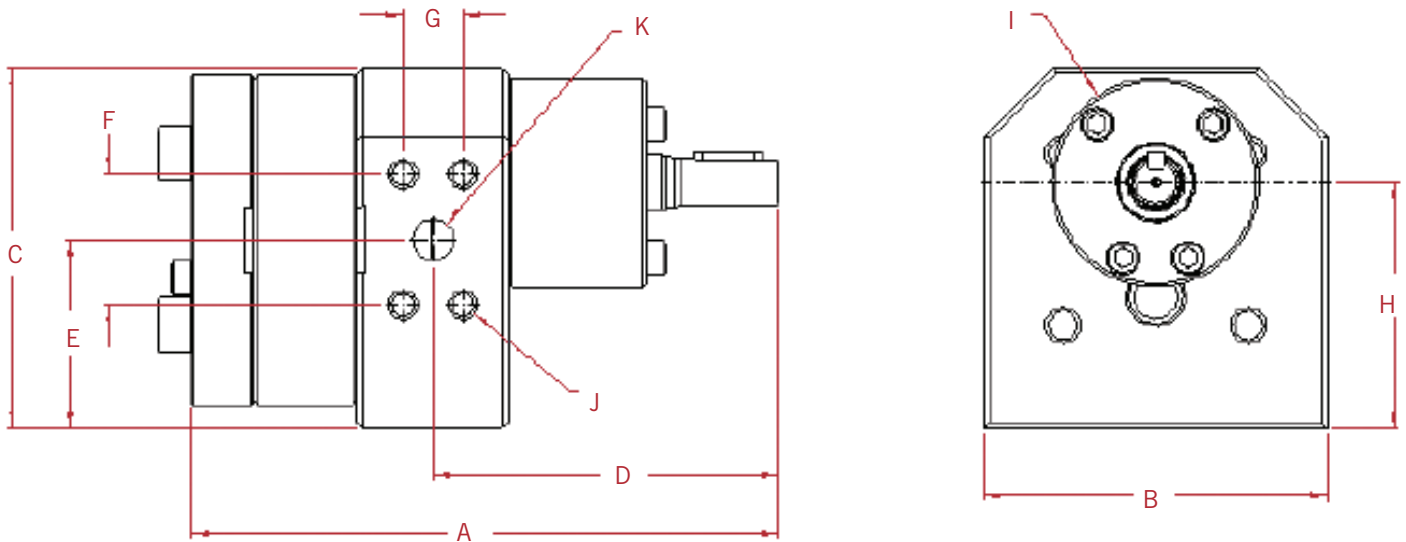

(in/mm)	A	B	C	D	E	F	G	H	I	J	K	PORTING FLANGE
0.05 cc/rev	4.69	2.76	2.95	3.37	1.57	-	-	2.04	1.83	-	M12 X 1.5	ISO 6149*
	119	70	75	86	40	-	-	51.8	46.5	-		
0.3 cc/rev	4.75	2.76	2.95	3.37	1.57	-	-	2.04	1.83	-	M12 X 1.5	ISO 6149*
	121	70	75	86	40	-	-	51.8	46.5	-		
0.6 cc/rev	4.85	2.76	2.95	3.37	1.57	-	-	2.04	1.83	-	M12 X 1.5	ISO 6149*
	123	70	75	86	40	-	-	51.8	46.5	-		
1.2 cc/rev	5.05	2.76	2.95	3.37	1.57	-	-	2.04	1.83	-	M12 X 1.5	ISO 6149*
	128	70	75	86	40	-	-	51.8	46.5	-		
2.4 cc/rev	5.44	2.76	2.95	3.37	1.57	-	-	2.04	1.83	-	M12 X 1.5	ISO 6149*
	138	70	75	86	40	-	-	51.8	46.5	-		
4.5 cc/rev	6.14	3.94	4.13	3.98	2.17	1.5	0.69	2.82	2.4	M8 X 1.25	0.47	13mm ISO 6162*
	156	100	105	101	55	38.1	17.5	71.67	61		12	
9 cc/rev	6.76	3.94	4.13	3.98	2.17	1.5	0.69	2.82	2.4	M8 X 1.25	0.47	13mm ISO 6162*
	172	100	105	101	55	38.1	17.5	71.67	61		12	
15 cc/rev	7.85	5	5.31	4.97	2.81	1.87	0.87	3.73	3.15	M10 X 1.5	0.75	19mm ISO 6162*
	199	127	135	126	71.5	47.6	22.2	94.8	80		19.1	
30 cc/rev	8.81	5	5.31	4.97	2.81	1.87	0.87	3.73	3.15	M10 X 1.5	0.75	19mm ISO 6162*
	224	127	135	126	71.5	47.6	22.2	94.8	80		19.1	
45 cc/rev	10.23	6.89	7.09	6.22	3.64	2.31	1.19	4.88	3.94	M12 X 1.75	1.19	32mm ISO 6162*
	260	175	180	158	92.5	58.7	30.2	124	100		30.18	
90 cc/rev	11.48	6.89	7.09	6.22	3.64	2.31	1.19	4.88	3.94	M12 X 1.75	1.19	32mm ISO 6162*
	292	175	180	158	92.5	58.7	30.2	124	100		30.18	

* Optional NPT, sanitary, and ANSI port adapters available

SELECTION

1. Select pump model

	B-9000	C-9000	H-9000
TYPICAL SERVICE	GENERAL CHEMICAL	CORROSIVE/POOR LUBRICITY	ABRASIVE/HIGH TEMPERATURE
MATERIALS	400 SERIES STAINLESS STEEL	316 STAINLESS STEEL*	TOOL STEEL
OUTLET PRESSURE	UP TO 1,000 PSI (70 BAR)	UP TO 1,000 PSI (70 BAR)	UP TO 2,500 PSI (175 BAR)
INLET PRESSURE	UP TO 300 PSI (20 BAR)	UP TO 300 PSI (20 BAR)	UP TO 1,000 PSI (70 BAR)
TEMPERATURE	UP TO 645° F (340° C) *	UP TO 350° F (175° C) **	UP TO 950° F (510° C) ***
VISCOSITY	1 cP OR GREATER	0.3 cP OR GREATER	1 cP OR GREATER
FLOW RATE	UP TO 27,000 CC/MIN	UP TO 9,000 CC/MIN	UP TO 27,000 CC/MIN
LUBRICITY	GOOD / EXCELLENT	POOR / GOOD / EXCELLENT	ABRASIVE / GOOD / EXCELLENT
FLUID COMPATIBILITY	MILDLY CORROSIVE	CORROSIVE	NON-CORROSIVE

* Materials can include: inconel, hastelloy, Al-6XN, silicon carbide, stellite, zirconia and others (consult factory)

** Dependent on shaft seal materials

*** With packing seal and high temperature fasteners

2. Select maximum operating speed

OPERATING CONDITIONS		SUGGESTED MAXIMUM SPEED (RPM)		
LUBRICITY	VISCOSITY	B-9000	C-9000	H-9000
EXCELLENT (OILS, ETC.)	< 1,000 cP	≤ 500	≤ 1,000	≤ 500
GOOD (POLYOLS, ETC.) TO EXCELLENT	1,000 < 10,000 cP	≤ 300	≤ 500	≤ 300
POOR (SOLVENTS, ETC.) TO EXCELLENT	> 10,000 cP	≤ 150	≤ 150	≤ 150
ABRASIVE (TiO ₂ , ETC. - CONSULT FACTORY)	> 1 cP	-	-	≤ 75

3. Select pump size

1. Maximum flow (cc/min) ÷ maximum operating speed = pump capacity (cc/rev)
2. Round up to the next largest pump. See previous page for available sizes.
3. Calculate minimum operating speed (RPM) = minimum flow (cc/min) ÷ pump capacity (cc/rev)

4. Select reducer ratio (all systems) or direct drive (magnetic drive systems only)

PUMP SPEED RANGE WITH 1,800 RPM MOTOR, 20:1 TURNDOWN							
SPEED RANGE (n - N)	90 - 1,800	29 - 576	13-249	18-343	8-155	7-123	5-87
REDUCER RATIO	1:1 (DIRECT)	3.12:1	7.23:1	5.24:1	11.55:1	14.57:1	20.62:1

SELECTION

5. Calculate maximum pump torque requirements

1. Pump torque:

$$T \text{ (in-lbs)} = (K_1 \cdot \Delta P \text{ (psi)}) + (K_2 \cdot N \cdot \mu / 100,000) \text{ or}$$

$$T \text{ (Nm)} = (K_3 \cdot \Delta P \text{ (kg/cm}^2\text{)}) + (K_4 \cdot N \cdot \mu / 100,000)$$

K_1, K_2, K_3, K_4 = constants from adjacent chart

ΔP = Differential Pressure (outlet pressure - inlet pressure)

N = Maximum pump speed, based on reducer ratio.

See step 4.

μ = Viscosity (cps). Note: for shear thinning fluids, consult Zenith.

2. Compare the calculated torque to the maximum torque shown in the adjacent chart. The calculated torque must not exceed the maximum torque.

3. For magnetic drive systems, the calculated torque cannot exceed the maximum torque rating of the magnetic coupling. See the Mag-Drive data sheet for torque limits and available system configurations.

Capacity (cc/rev)	K_1 / K_2	K_3 / K_4	MAX TORQUE * (IN-LBS/NM)
0.05	0.0005 / 0.85	0.0008 / 0.096	10 / 1.1
0.3	0.003 / 2.11	0.004 / 0.24	90 / 10
0.6	0.006 / 2.34	0.010 / 0.26	200 / 23
1.2	0.012 / 2.82	0.018 / 0.32	200 / 23
2.4	0.023 / 3.78	0.037 / 0.43	200 / 23
4.5	0.044 / 6.85	0.070 / 0.77	400 / 45
9	0.087 / 8.56	0.141 / 0.97	400 / 45
15	0.146 / 14.66	0.233 / 1.66	600 / 68
30	0.291 / 18.57	0.468 / 2.10	600 / 68
45	0.437 / 32.78	0.701 / 3.70	1950 / 220
90	0.873 / 30.61	1.404 / 3.46	1950 / 220

* Add 20% to Max. Torque limit for 400 Series SS

6. Calculate system HP

1. $HP = T / (35 \cdot 0.85 \cdot R)$

T = Maximum torque (in lbs) from step 5

R = Reducer ratio from step 4

(for example, if 7.23:1 use 7.23)

OR

$$KW = T / (5.3 \cdot 0.85 \cdot R)$$

T = Maximum torque (Nm) from step 5

R = Reducer ratio from step 4

(for example, if 7.23:1 use 7.23)

2. Round up to the next highest motor horse power available, i.e. calculated HP = 0.33, select 1/2 HP motor. See the standard metering system data sheet for configurations available based on pump size and horsepower.

7. Check pump efficiency

Based on application conditions, verify that the efficiency of the pump is acceptable. For high pressure and low viscosity applications, it may be necessary to increase pump speed or pump capacity. Contact Zenith for assistance.

1. Use the formula shown below the x-axis to calculate a value.
2. Using the value calculated, trace a line vertically until the appropriate pump curve is intersected.
3. Trace a line horizontally to the left to obtain a value for the derating factor.
4. Multiply the derating factor by the theoretical flow, $N \text{ (RPM)} \cdot \text{pump size (cc/rev)}$, to obtain estimated actual flow (cc/min).

B-9000 or H-9000 pump performance

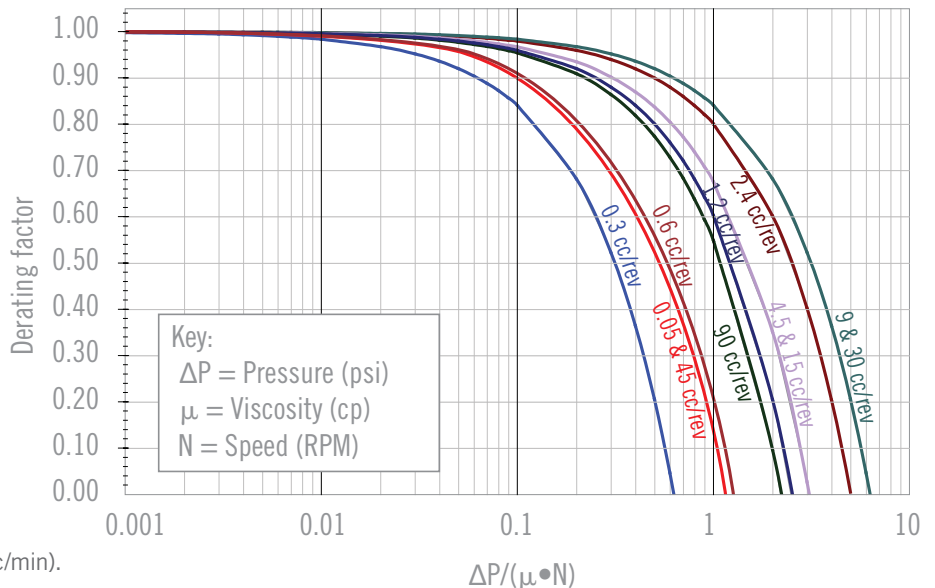

* Add 20% to Max. Torque limit for 400 Series SS

SELECTION

8. Check inlet pressure requirements

In order to prevent cavitation and ensure successful operation, sufficient inlet pressure must be available at the inlet pump. Based on maximum viscosity and maximum operating speed, verify that the inlet pressure available exceeds the net inlet pressure required (NIPR) plus the liquid vapor pressure.

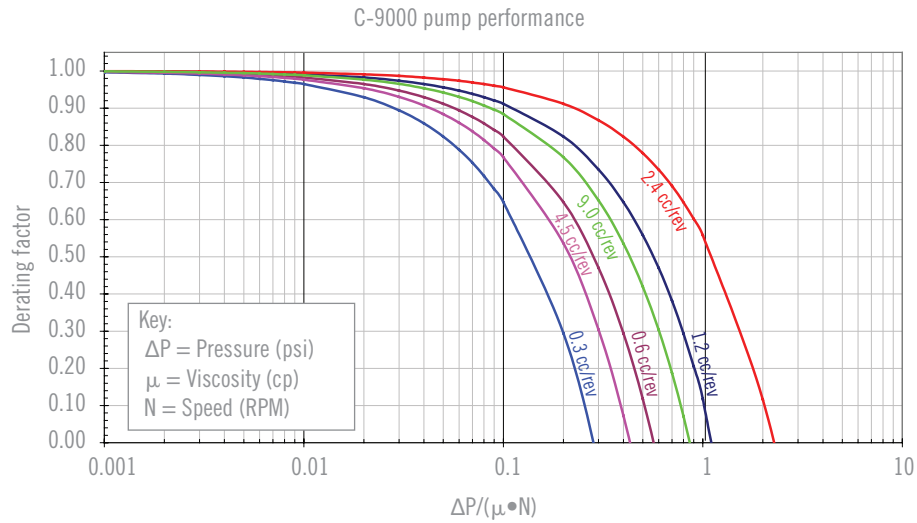

(cc/rev)	W1	W2
0.05	2.19 E-06	1.37 E-05
0.3	4.29E-06	2.32E-06
0.6	1.93E-06	2.47E-06
1.2	1.21E-06	2.77E-06
2.4	9.34E-07	3.38E-06
4.5	3.00E-07	3.46E-07
9	2.24E-07	4.19E-07
15	1.11E-07	7.47E-08
30	8.61E-08	9.28E-08
45	3.38E-08	1.65E-08
90	2.49E-08	2.02E-08

$NIPR (psi^*) = \text{Viscosity (cps)} \cdot \text{Displacement (cc/rev)} \cdot \text{Shaft speed (RPM)} \cdot [(\text{Specific gravity} \cdot W1) + W2]$

*NIPR is considered to be a differential pressure, so units are "psi" or "psid".

Inlet Pressure Required** = NIPR + Liquid Vapor Pressure

** The units used for liquid vapor pressure (psia or psig) will determine the units for the inlet pressure required.

Note: This sizing procedure should be used as a guideline for pump selection. Please consult Zenith or your local authorized representative to confirm your selection prior to placing an order.



CIRCOR is a market-leading, global provider of integrated flow control solutions, specializing in the manufacture of highly engineered valves, instrumentation, pumps, pipeline products and services, and associated products, for critical and severe service applications in the oil and gas, power generation, industrial, process, maritime, aerospace, and defense industries.

Excellence in Flow Control

Asia | Europe | Middle East | North America | South America



circorpt.com/zenith

CIRCOR
1710 Airport Rd
Monroe, NC 28110
USA