

**TORQUE CHART**

**M6 BOLTS LUBRICATED = 70 lb.-in. (7.9 N-m)**

**M4 BOLTS LUBRICATED = 20 lb.-in. (2.3N-m)**

**M10 BOLTS (MOUNTING) LUBRICATED = 335 lb.-in. (37.8 N-m)**

REVISIONS			
LTR	DESCRIPTION	DATE	ECN NO.
B	PLUG WAS 18-73000-0007-1	07/24/07	127-2007

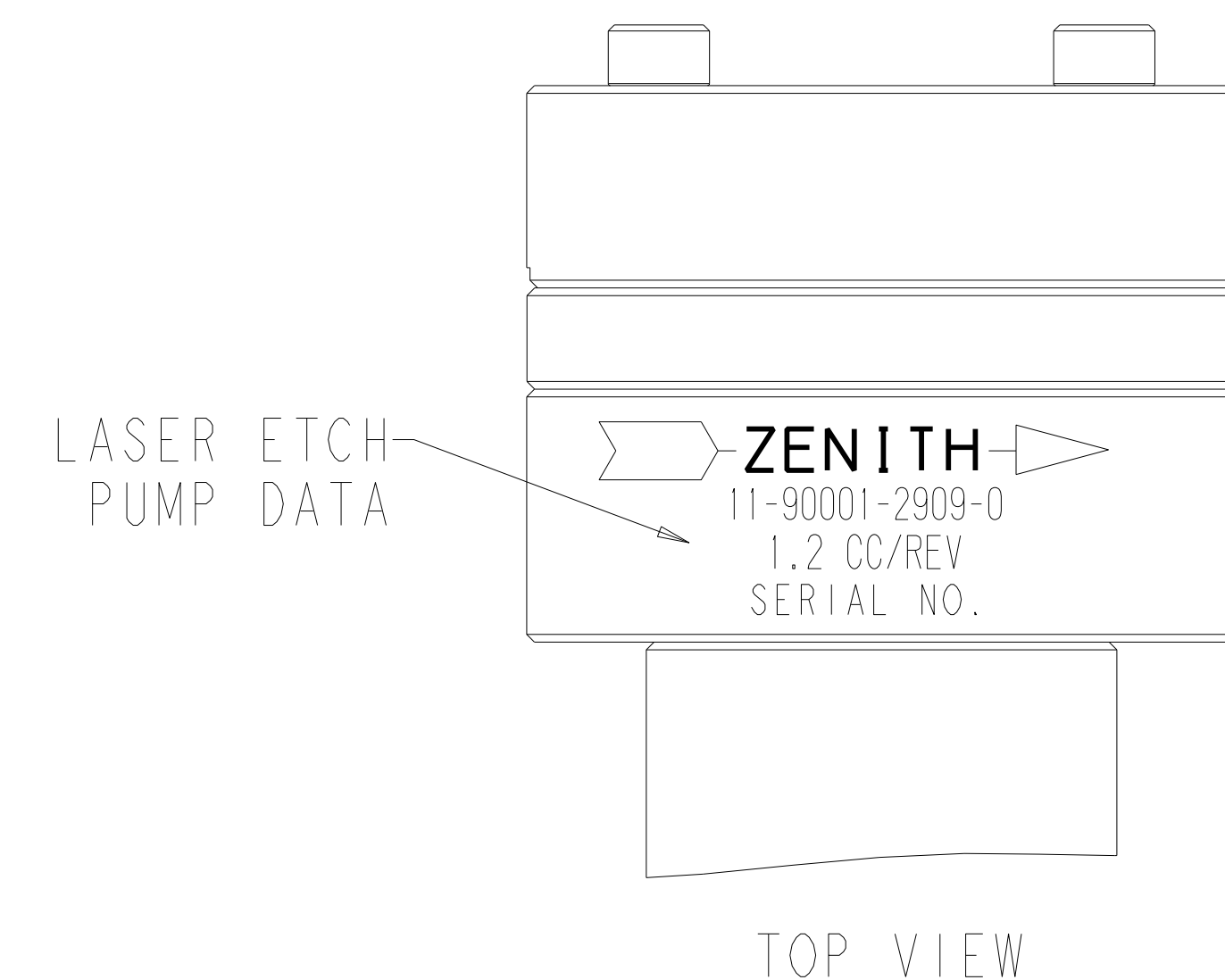
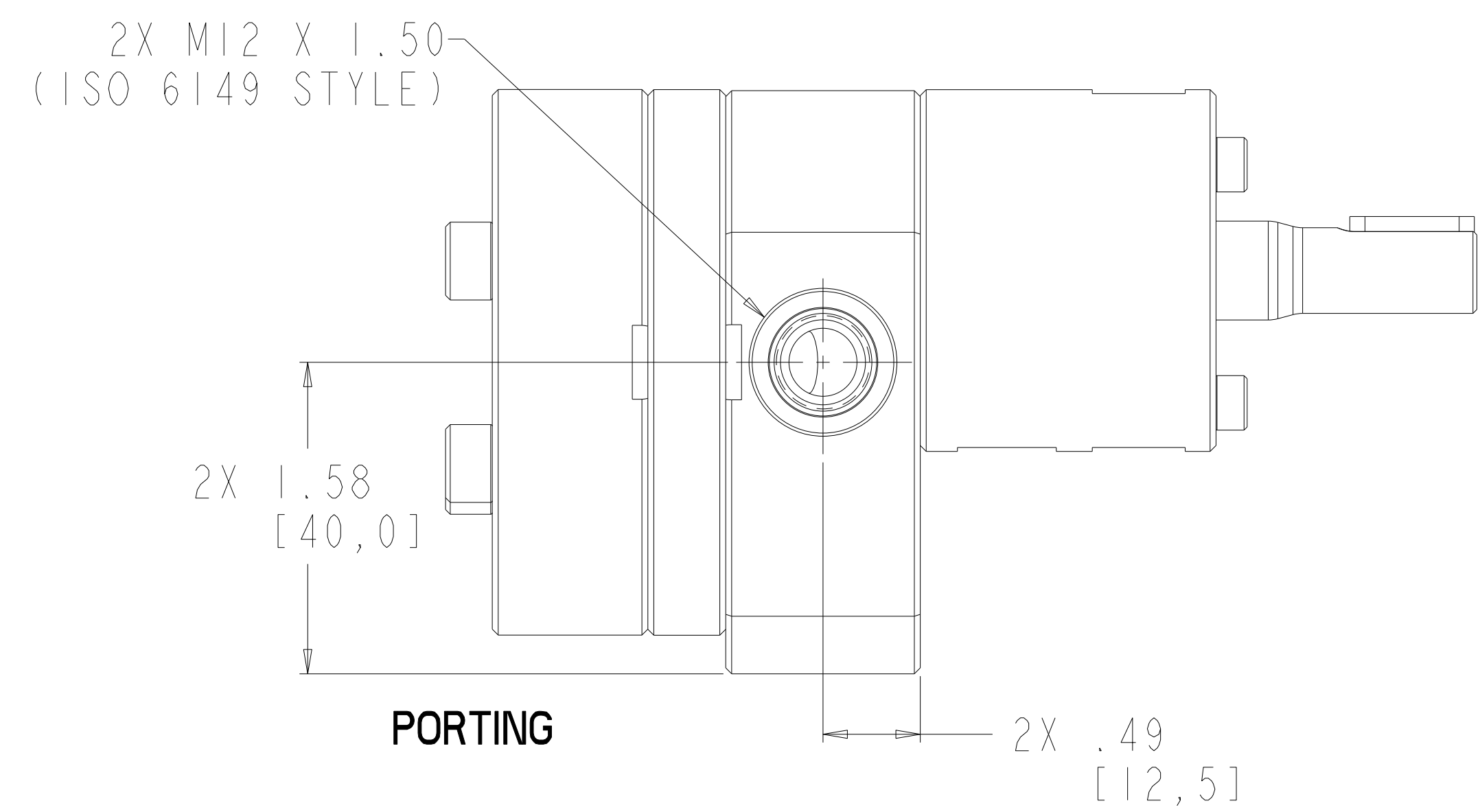
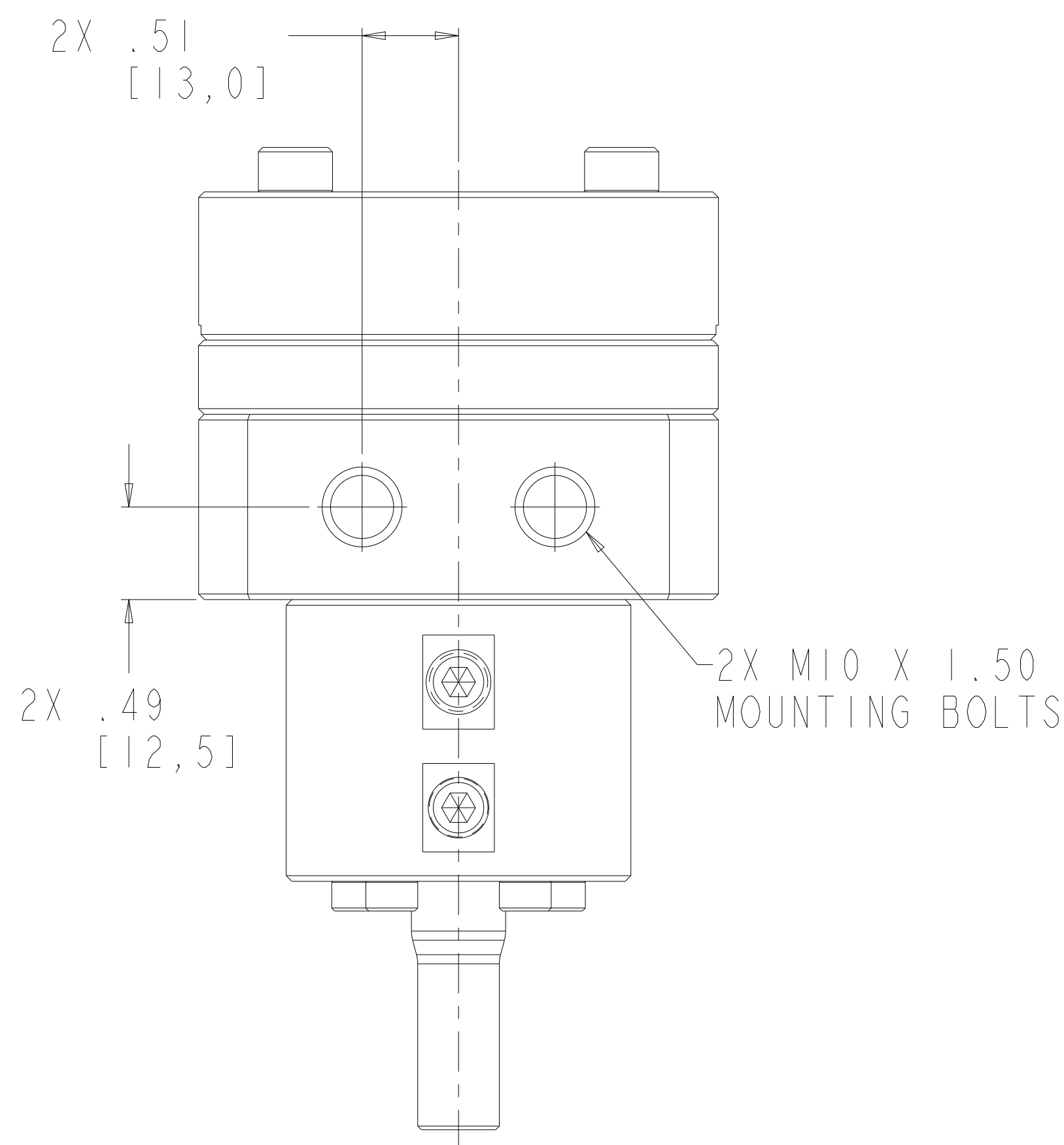
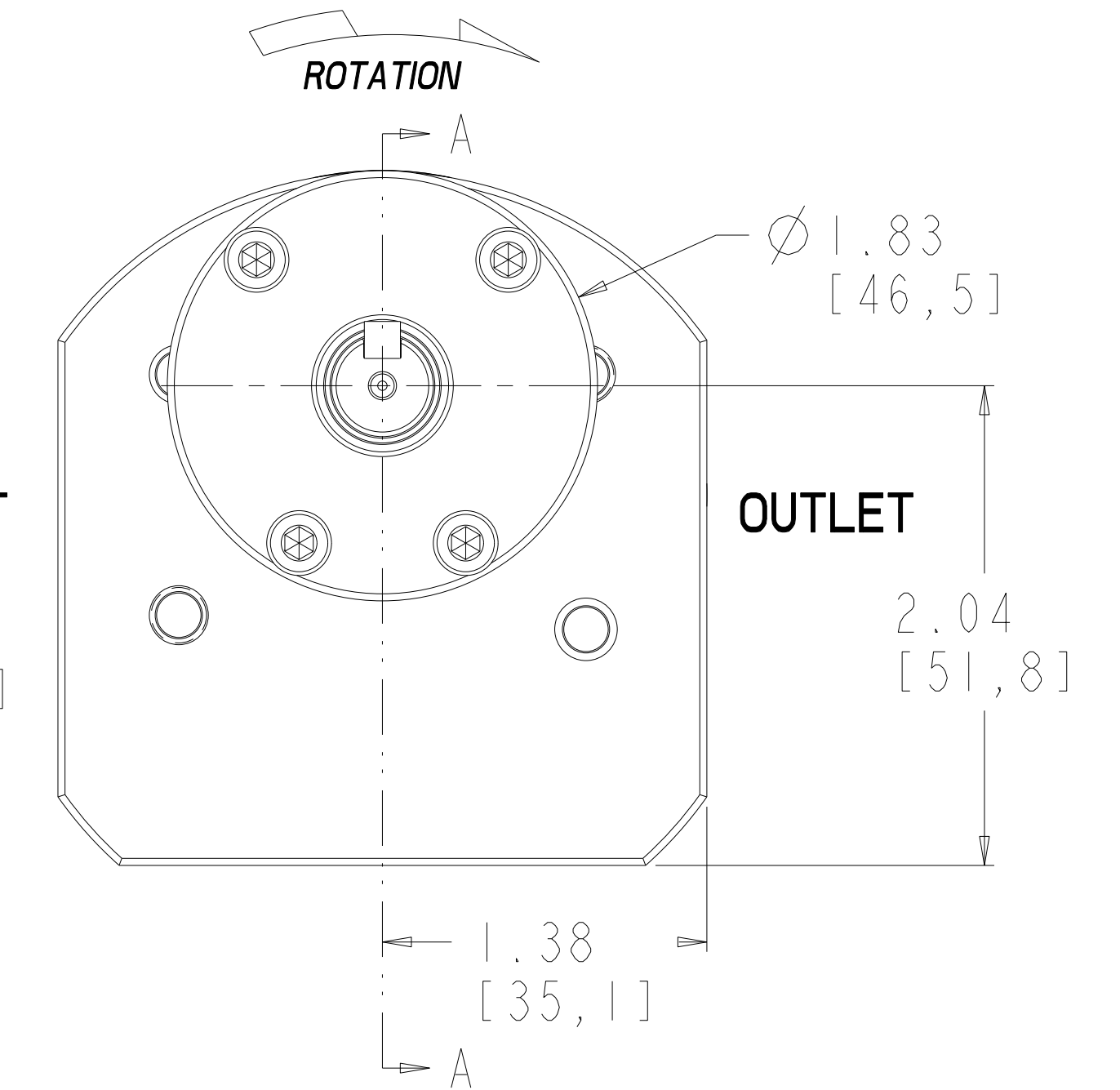
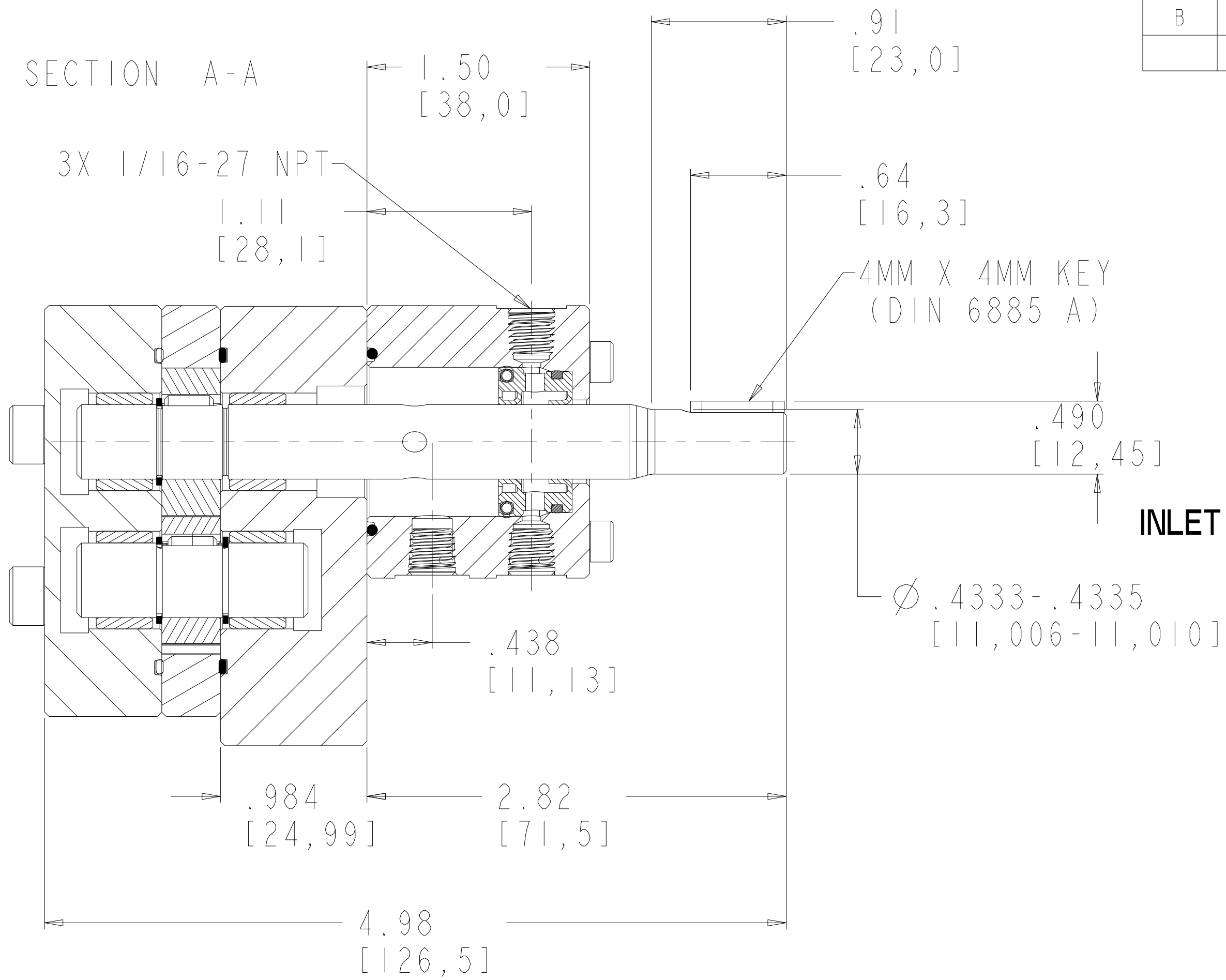
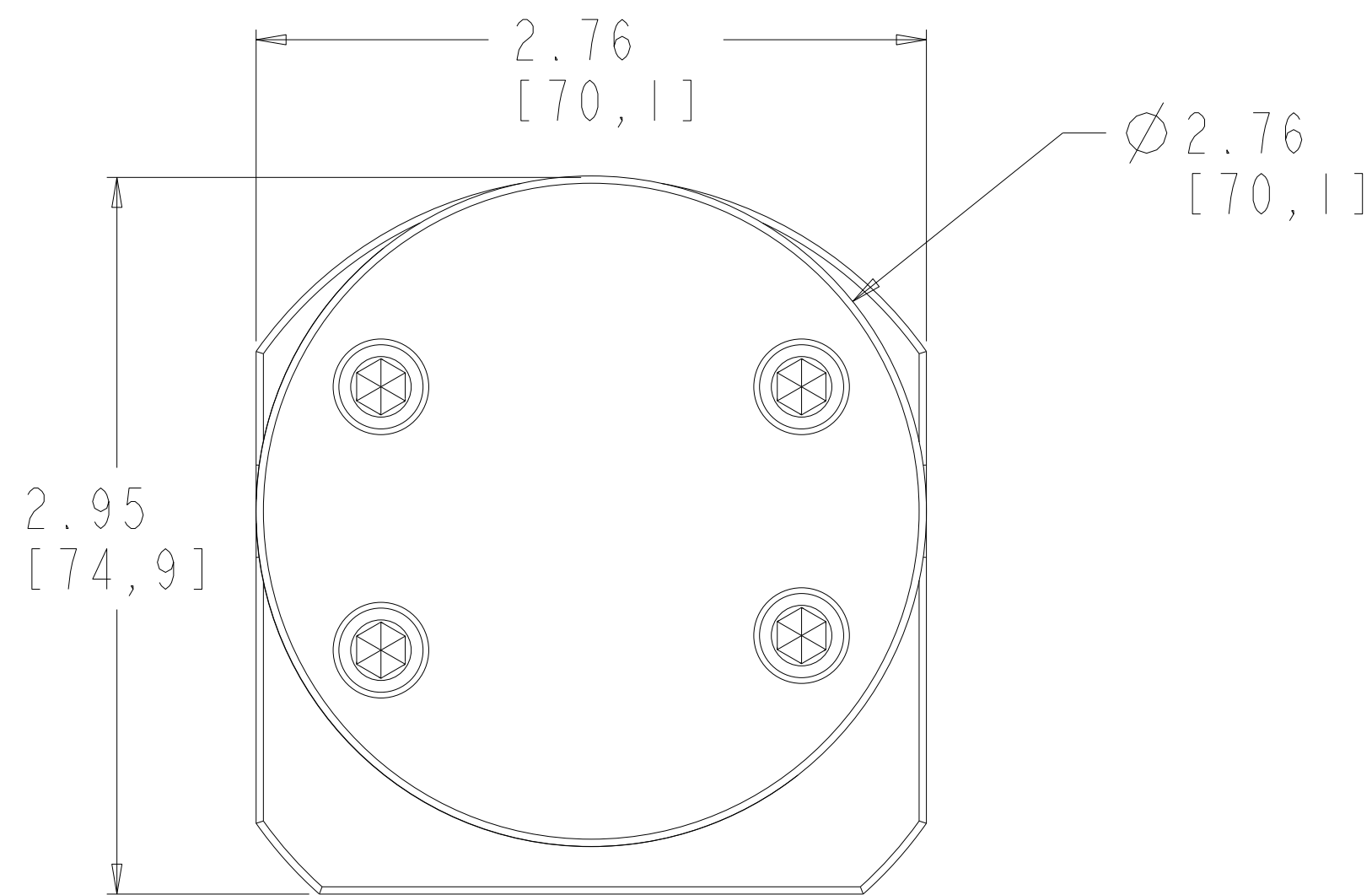

INTERPRET PER ASME-Y14.5M 1994

<p>THIS DOCUMENT CONTAINS INFORMATION THAT IS CONFIDENTIAL AND PROPRIETARY TO ZENITH PUMPS, COLFAX CORPORATION "COLFAX". THIS DOCUMENT IS FURNISHED ON THE UNDERSTANDING THAT THE DOCUMENT AND THE INFORMATION IT CONTAINS WILL NOT BE COPIED OR DISCLOSED TO OTHERS OR USED FOR ANY PURPOSE OTHER THAN CONDUCTING BUSINESS WITH COLFAX, AND WILL BE RETURNED AND ALL FURTHER USE DISCONTINUED UPON REQUEST BY COLFAX.</p>	<p>UNLESS OTHERWISE SPECIFIED DIMENSIONS ARE IN INCH TOLERANCES</p> <p>.XX ± 0.01 .XXX ± 0.005 ANG ± 0.5</p>	DRAWN LG	5.15.2003	<p><b>ZENITH PUMPS</b> 5910 ELWIN BUCHANAN DRIVE SANFORD, NC 27330</p>
		CHECKED		
<p>MATERIAL</p> <p>SEE BILL OF MATERIAL ON SHEET 2 OF 3</p>		PART WEIGHT =	LBS	<p>C-9000-1.2CC/REV-RAN 909 1.2 CC/REV RANDOM 909</p>
		SURFACE AREA =	IN^2	
		PRO/ENGINEER DRAWING	SIZE D	SCALE 3:2 SHEET 1 OF 3

ITEM No.	PART NUMBER	PART NAME	MATERIAL	QTY
	119000129090	C-9000-1.2CC/REV-RAN 909		1
5	152020901632	GEAR, DRIVING	ZP2724	2
16	181831800122	RING - RETAINING	PH 15-7 MO	3
2	157956800502	SHAFT, DRIVE	ZP2724	1
3	156925100384	PLATE, GEAR	316SS PER MAT 306	1
7	146915100112	ASSEMBLY, REAR PLATE		1
20	156915100274	PLATE, REAR	ZP1222	1
23	150453100031	BEARING, SLEEVE	ZP1186	2
34	187650402101	O-RING	PTFE ENCAPSULATED	2
8	146945200112	ASSEMBLY, FRONT PLATE		1
21	156945200294	PLATE, FRONT	ZP1222	1
24	150453100031	BEARING, SLEEVE	ZP1186	2
10	151609100621	DOWEL, HOLLOW	17-4PH	2
4	155600205741	KEY, ROUND	AISI 316SS	2
11	155401900493	HOUSING, SEAL	ZP1222	1
33	187650402091	O-RING	PTFE ENCAPSULATED	1
19	189340610502	SHCS M6X1 X 50MM 316 SS		4
17	185600800061	KEY, SQUARE W/RND ENDS	STEEL 50-1K	1
18	189340410452	SHCS M4X0.7 X 45 MM 316 SS		4
50	147900400142	SUB-ASSY, LIP SEAL & TOOL		1
52	150013100642	SEAL ASSEMBLY TOOL	ACETAL COPOLYMER	1
51	147900400232	TANDEM LIP SEAL	CARBON FIBER FILLED	1
35	187300000161	PLUG, DRYSEAL TYPE	316 S.S.	3
9	150115600312	ARBOR	ZP2724	1

REVISIONS			
LTR	DESCRIPTION	DATE	ECN NO.
B	PLUG WAS 18-73000-0007-1	07/24/07	127-2007

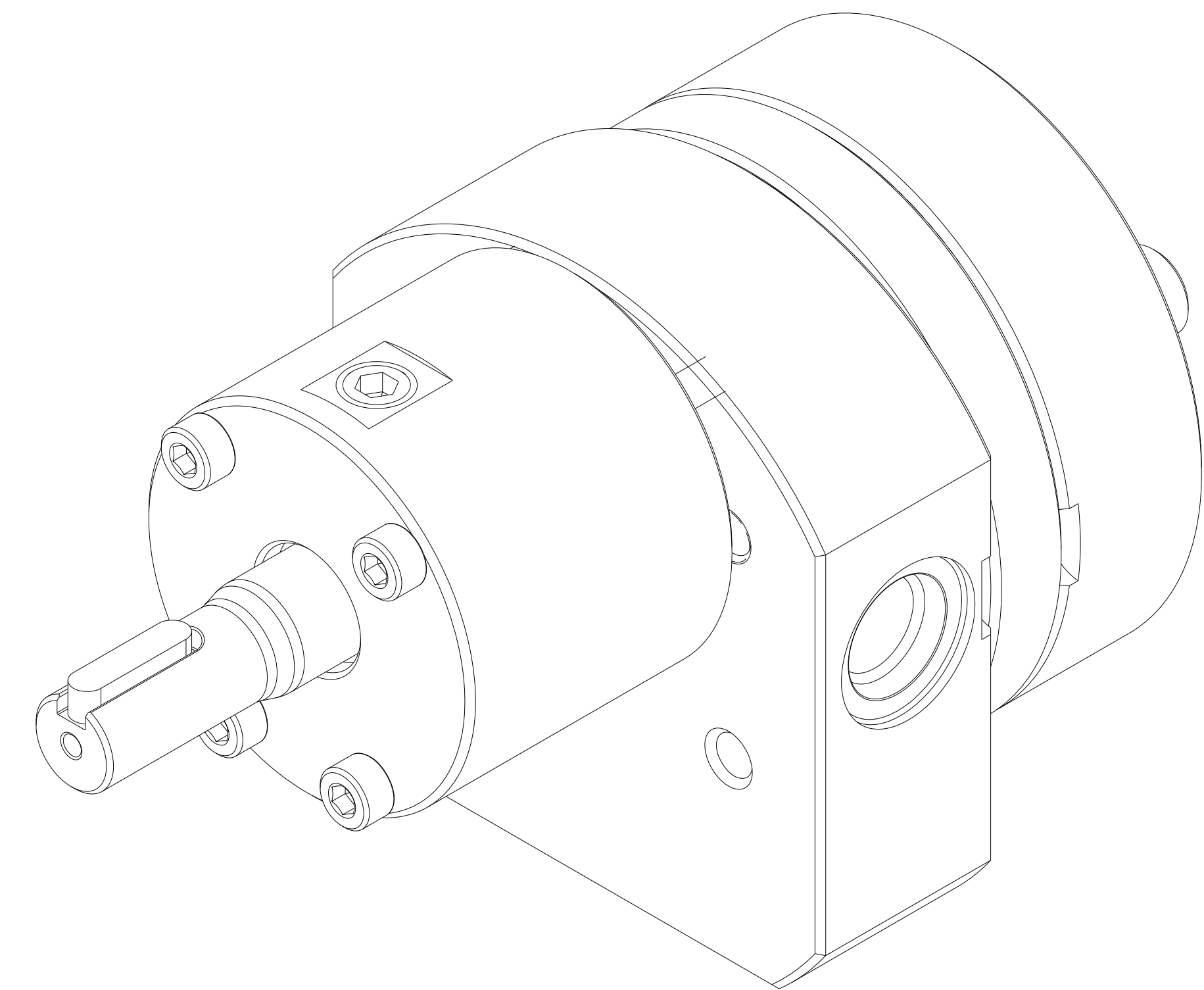

INTERPRET PER ASME-Y14.5M 1994

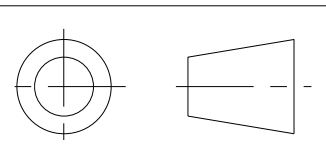

<small>THIS DOCUMENT CONTAINS INFORMATION THAT IS CONFIDENTIAL AND PROPRIETARY TO ZENITH PUMPS, COLFAX CORPORATION "COLFAX". THIS DOCUMENT IS FURNISHED ON THE UNDERSTANDING THAT THE DOCUMENT AND THE INFORMATION IT CONTAINS WILL NOT BE COPIED OR DISCLOSED TO OTHERS OR USED FOR ANY PURPOSE OTHER THAN CONDUCTING BUSINESS WITH COLFAX, AND WILL BE RETURNED AND ALL FURTHER USE DISCONTINUED UPON REQUEST BY COLFAX.</small>	<small>UNLESS OTHERWISE SPECIFIED DIMENSIONS ARE IN INCH TOLERANCES</small> .XX ± 0.01 .XXX ± 0.005 ANG ± 0.5	DRAWN LG	5.15.2003	 <b>ZENITH PUMPS</b> 5910 ELWIN BUCHANAN DRIVE SANFORD, NC 27330
		CHECKED		
MATERIAL SEE BILL OF MATERIAL ON SHEET 2 OF 3		MODEL NUMBER = 119000129090 DRAWING = 119000129090		C-9000-1.2CC/REV-RAN 909 1.2 CC/REV RANDOM 909
		PRO/ENGINEER DRAWING	SIZE D	SCALE 2:1 SHEET 2 OF 3 DRAWING NUMBER 11-90001-2909-0

REVISIONS			
LTR	DESCRIPTION	DATE	ECN NO.
B	PLUG WAS 18-73000-0007-1	07/24/07	127-2007

**TORQUE CHART**

**M6 BOLTS LUBRICATED = 70 lb.-in. (7.9 N-m)**

**M4 BOLTS LUBRICATED = 20 lb.-in. (2.3N-m)**

**M10 BOLTS (MOUNTING) LUBRICATED = 335 lb.-in. (37.8 N-m)**

LUBRICATE O-RINGS WITH PARKER O-RING LUBE PRIOR TO ASSEMBLY.

LUBRICATE UNDERSIDE OF CAP & THREADS ON FASTENERS WITH ANTI-SEIZE COMPOUND PRIOR TO ASSEMBLY.

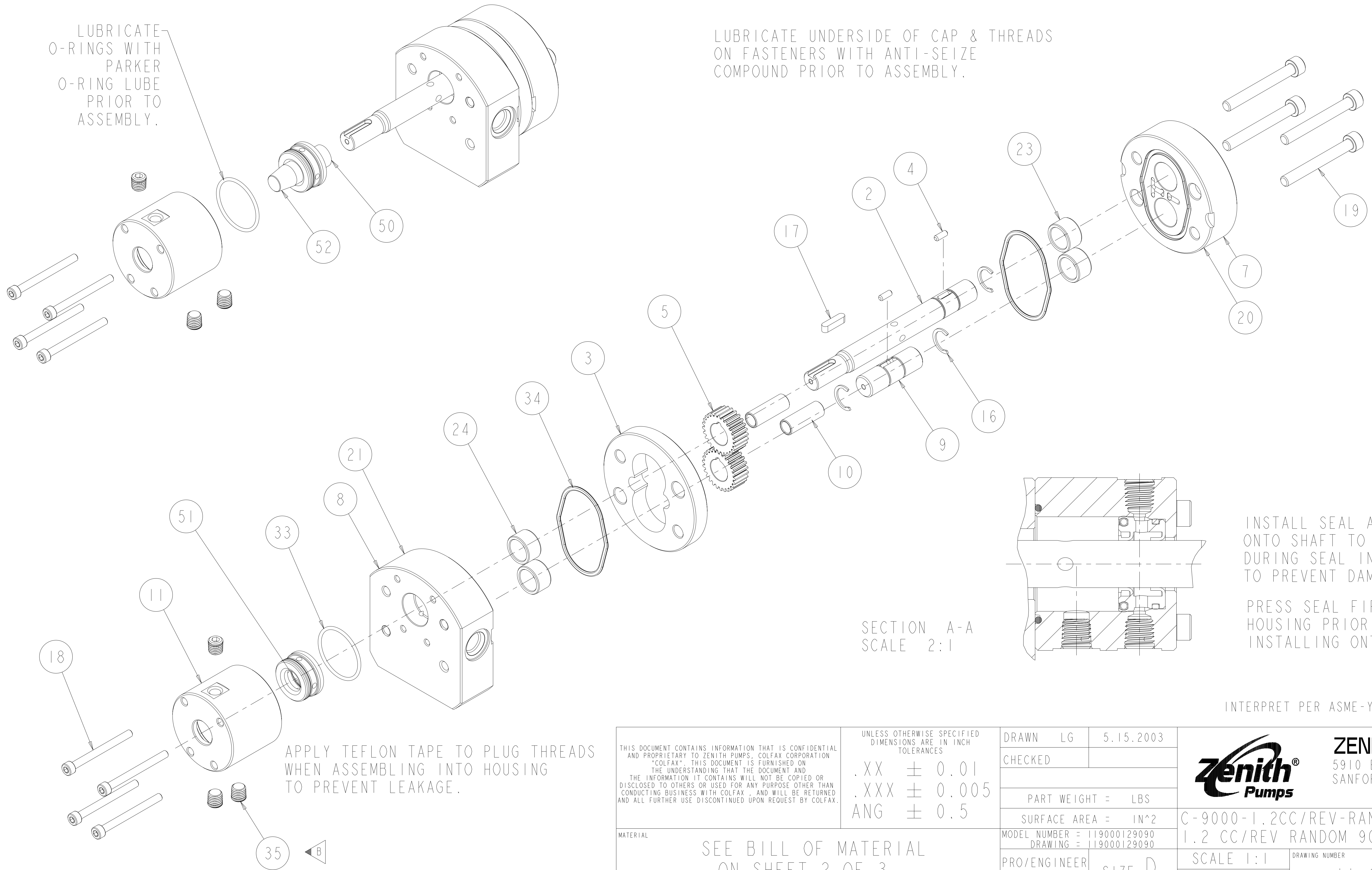

SECTION A-A  
SCALE 2:1

INSTALL SEAL ASSEMBLY TOOL ONTO SHAFT TO COVER KEYWAY DURING SEAL INSTALLATION, TO PREVENT DAMAGE.

PRESS SEAL FIRMLY INTO HOUSING PRIOR TO INSTALLING ONTO PUMP.

INTERPRET PER ASME-Y14.5M 1994

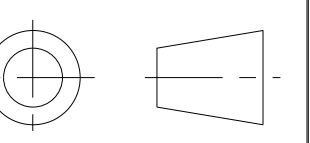

APPLY TEFLON TAPE TO PLUG THREADS WHEN ASSEMBLING INTO HOUSING TO PREVENT LEAKAGE.

<small>THIS DOCUMENT CONTAINS INFORMATION THAT IS CONFIDENTIAL AND PROPRIETARY TO ZENITH PUMPS, COLFAX CORPORATION "COLFAX". THIS DOCUMENT IS FURNISHED ON THE UNDERSTANDING THAT THE DOCUMENT AND THE INFORMATION IT CONTAINS WILL NOT BE COPIED OR DISCLOSED TO OTHERS OR USED FOR ANY PURPOSE OTHER THAN CONDUCTING BUSINESS WITH COLFAX, AND WILL BE RETURNED AND ALL FURTHER USE DISCONTINUED UPON REQUEST BY COLFAX.</small>	<small>UNLESS OTHERWISE SPECIFIED DIMENSIONS ARE IN INCH TOLERANCES</small> .XX ± 0.01 .XXX ± 0.005 ANG ± 0.5		DRAWN LG 5.15.2003 CHECKED	<b>ZENITH PUMPS</b> 5910 ELWIN BUCHANAN DRIVE SANFORD, NC 27330
	MATERIAL SEE BILL OF MATERIAL ON SHEET 2 OF 3		PART WEIGHT = LBS SURFACE AREA = IN <sup>2</sup> MODEL NUMBER = 119000129090 DRAWING = 119000129090	
			PRO/ENGINEER DRAWING SIZE D	SCALE 1:1 SHEET 3 OF 3
			DRAWING NUMBER 11-90001-2909-0	