

# Introducing the 9000MD Mag-Coupled Gear Pump from Zenith Pumps.

Zenith Metering Pumps were introduced in the late 1920's to provide precise, repeatable, and pulseless fluid flow under varying process conditions. Since 1926, Zenith established a worldwide standard of excellence for innovative gear metering pump designs that are consistently used in the most critical fluid metering applications. Zenith's 9000MD again shows our commitment to industry that Zenith can provide quality products and services needed in order to meet today's rigorous demands.

The 9000MD offers a static seal alternative to traditional mechanical and compression type dynamic seals. A permanent magnetic coupling transmits torque by magnetic forces between the internal and external rotors, through a statically sealed barrier. The barrier is constructed from stainless steel, nickel alloy or other corrosion resistant material and is not contacted by either the inner or outer rotor.

The pump head is coupled to NEMA 56C/140TC framed motors, either AC or DC, which allows the motor to be removed from the pump housing without difficulty. Pump speeds are limited based on the pump of choice. The system can be close coupled without the need of a gear reducer.

The 9000MD eliminates shaft leakage of hazardous fluids, increases plant safety, and reduces VOC emissions. The magnetic coupling also reduces downtime due to excessive mechanical seal failures and eliminates the need for buffer fluids.

Zenith's magnetically coupled pump designs include the B-9000 and C-9000 models. The B-9000 pumps are made of through hardened 400 series SS while the C-9000 is constructed from hardened 316 SS/compatible materials. This new seal design can be retrofitted to any existing B- or C-9000 pump ranging from 0.05 to 9.0 cc/rev. Zenith's C-9000 is primarily used for non-lubricating, corrosive and/or thin fluids, where 316 SS compatible materials of construction are usually desired. The B9000 is considered a chemical duty metering pump suitable for a variety of chemical metering applications.

## Mag-Coupled 9000 Series Gear Metering Pump Precision Hazardous Fluid Handling Solution



[zenithpumps.com](http://zenithpumps.com)

Magnetic coupling affords safe operation while precisely metering dangerous fluids

- **Eliminates shaft seal leakage**—No fugitive emission whatsoever, no leak to capture, nothing to clean-up
- **Eliminates shaft seal wear**—No daily adjustment of packing, no shut-down for seal replacement.
- **Eliminates the need for double seals and buffer liquids**— No contact between liquid and external atmosphere, no precipitation or freezing at the seal.
- **Meets Hazardous Atmospheres Equipment Requirements** — Meets OSHA, EPA, CSA regulations
- **Corrosion resistant**— Stationary can and internal rotor of 316 stainless steel, titanium stabilized

Zenith® Pumps— over 75 years of experience in industrial flow control technology

Ph: 919-774-7667 • Fax: 919-774-5952

Email: [zenithpumps@parker.com](mailto:zenithpumps@parker.com)

Isocyanates  
Solvents

Organic  
Compounds  
Volatile



Magnetic Coupling Pump Options/ Capabilities:	<i>B-9000 Series - Industrial Duty Constructed of through hardened 400 series Stainless Steel</i>	<i>C-9000 Corrosive/Non-Lubricating Constructed of hardened 316 SS and compatible materials</i>
<b>Capacities:</b>	0.05, 0.3, 0.6, 1.2, 2.4, 4.5, 9.0	0.3, 0.6, 1.2, 2.4, 4.5, 9.0
<b>Recommended Speeds:</b>	Up to 500 RPM	Up to 1000 RPM
<b>Flow Range:</b>	Up to 4500 cc/min or up to 1.2 GPM	Up to 9000 cc/min or up to 2.4 GPM
<b>Inlet Pressure:</b>	300 Psi (20 Bar) Maximum	300 Psi (20 Bar) Maximum
<b>Outlet Pressure:</b>	1000 Psi (70 Bar) Maximum	1000 Psi (70 Bar) Maximum
<b>Differential Pressure:</b>	20 to 1000 Psi (viscosity dependent)	20 to 1000 Psi (viscosity dependent)
<b>Temperature:</b>	0°F (-18° C) Minimum 400° F (205° C) Maximum	-15° F (-25° C) Minimum 350° F (175° C) Maximum
<b>Seal Type:</b>	Rare Earth - Samarium Cobalt Magnets	Rare Earth - Samarium Cobalt Magnets
<b>Port Connections:</b>	Metric thread or SAE 61 Standard	Metric thread or SAE 61 Standard
<b>Optional Port Adapters:</b>	M12 X 1/4" NPT 0.05 - 2.4 cc/rev 1/2" SAE X 1/2" NPT 4.5 - 9.0 cc/rev	M12 X 1/4" NPT 0.3 - 2.4 cc/rev 1/2" SAE X 1/2" NPT .4.5 - 9.0 cc/rev

**1/2 HP AC  
No Reducer  
1.2 cc/rev**

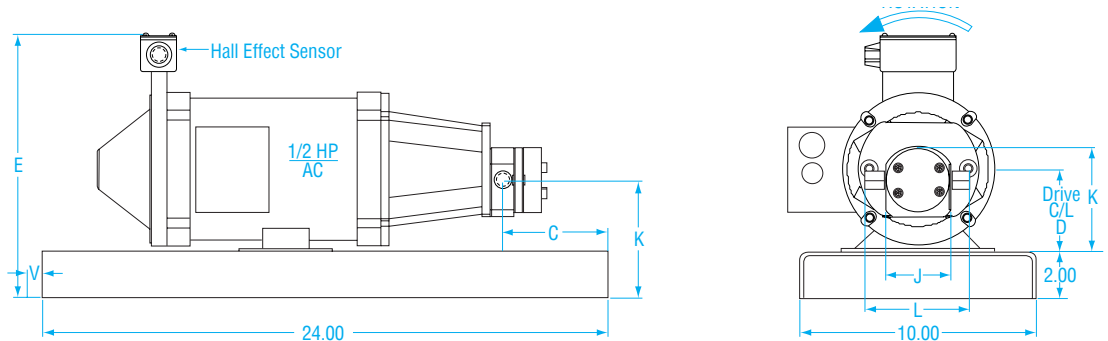

**2 HP AC  
with Reducer  
9.0 cc/rev**

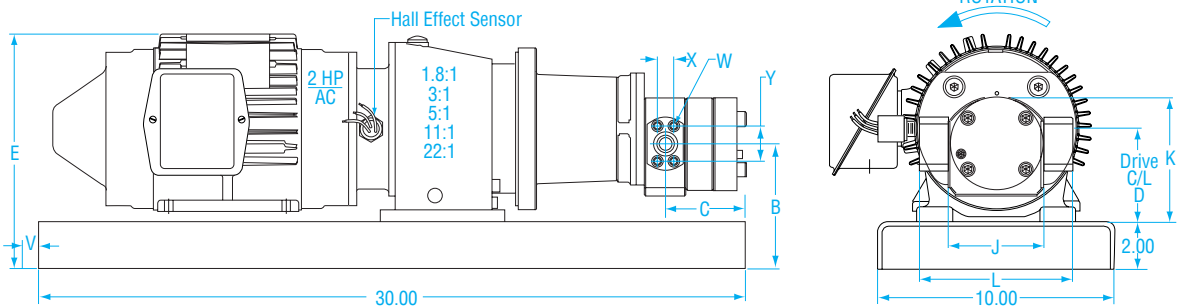

**Note:** Either system also available with ZeDrive™ DC controllers and motors. For more information, please visit [www.zenithpumps.com](http://www.zenithpumps.com)

System Configuration	Magnetic Coupling	B	C	D	E	J	K	L	DC Motor Overhang, V	W	X	Y	Motor NEMA
0.5 - 2.4 cc/rev 1/2 HP AC/DC, No Reducer	23 in-lb	5.01	4.50	5.47	11.2	2.76	4.38	4.45	N/A	N/A	N/A	N/A	56-C
0.5 - 2.4 cc/rev 1/2 HP AC/DC, with Reducer	23 in-lb	5.47	4.50	5.94	11.7	2.76	4.85	4.45	N/A	N/A	N/A	N/A	56-C
0.5 - 2.4 cc/rev 1 HP AC/DC, No Reducer	55 in-lb	5.01	4.50	5.47	11.2	2.76	4.38	4.45	N/A	N/A	N/A	N/A	56-C
0.5 - 2.4 cc/rev 1 HP AC/DC, with Reducer	55 in-lb	5.47	4.50	5.94	11.7	2.76	4.85	4.45	0.09	N/A	N/A	N/A	56-C
4.5 - 9.0 cc/rev 1/2 HP AC/DC, No Reducer	110 in-lb	4.84	4.00	5.47	11.2	3.94	4.81	6.5	N/A	M8 x 12DP	0.69	1.5	56-C
4.5 - 9.0 cc/rev 1/2 HP AC/DC, with Reducer	110 in-lb	5.28	3.44	5.94	11.7	3.94	5.25	6.5	N/A	M8 x 12DP	0.69	1.5	56-C
4.5 - 9.0 cc/rev 1 HP AC/DC, No Reducer	110 in-lb	4.84	4.00	5.47	11.2	3.94	4.81	6.5	0.06	M8 x 12DP	0.69	1.5	56-C
4.5 - 9.0 cc/rev 1 HP AC/DC, with Reducer	110 in-lb	5.28	3.44	5.94	11.7	3.94	5.25	6.5	0.17	M8 x 12DP	0.69	1.5	56-C
4.5 - 9.0 cc/rev 2 HP AC/DC, No Reducer	110 in-lb	4.84	4.00	5.47	11.2	3.94	4.81	6.5	3.36	M8 x 12DP	0.69	1.5	140TC
4.5 - 9.0 cc/rev 2 HP AC/DC, with Reducer	110 in-lb	5.28	3.44	5.94	11.7	3.94	5.25	6.5	2.77	M8 x 12DP	0.69	1.5	140TC

Zenith® Pumps • 1710 Airport Road • Monroe, NC 28110 USA  
Phone: 877-853-7867  
[www.zenithpumps.com](http://www.zenithpumps.com) • e-mail: [cc@colfaxcorp.com](mailto:cc@colfaxcorp.com)

